

ILLUSTRATION SHOWS TYPICAL PARTS ONLY. ORDER BY PART NUMBER. PARTS NOT LISTED ARE SUPPLIED BY OEM.



| Ref # | Part Number | Qty | Description |
|-------|-------------|-----|---|
| 1 | 32586C | | Cylinder (Incl. 2, 3, 4 & 76) (2-3/4" Bore) |
| 2 | 27652 | | Pin, Dowel |
| 3 | 27642 | | Plug, Oil drain |
| 4 | 32630 | | Seal, Oil |
| 5 | 32783 | | Intake Valve (Std.) (Incl. 9) |
| 5 | 32784 | | Intake Valve (1/32" OS) (Incl. 9) |
| 6 | 27878A | | Exhaust Valve (Std.) (Incl. 9) |
| 6 | 27880A | | Exhaust Valve (1/32" OS) (Incl. 9) |
| 7 | 27882 | | Cap, Upper valve spring |
| 7A | 20810 | | Pin, Valve spring retainer (Use as re quired) |
| 8 | 27881 | | Spring, Valve |
| 8A | 27881 | | Spring, Valve |
| 9 | 32581 | | Cap, Lower valve spring |
| 9A | 32581 | | Cap, Lower valve spring |
| 10 | 34242 | | Dipper, Oil |
| 10A | 32590 | | Plate, Lock & Oil dipper (This plate may be replaced by 34242 oil dipper but 650662C screw must be used.) |
| 11 | 32680A | | Crankshaft (Incl. 12 & 13) |
| 12 | 29783 | | Crankshaft Gear Pin (Early production) |
| 13 | 27884 | | Gear, Crankshaft (Used in early produ ction) This gear is servicable onlywhen it is pinned to the crankshaft. |
| 14A | 32592B | | Piston & Pin Ass'y. (Std.)(2-3/4")(In cl.16) |
| 14A | 32593B | | Piston & Pin Ass'y. (.010" OS) (Incl. 16) |
| 14A | 32594B | | Piston & Pin Ass'y. (.020" OS) (Incl. 16) |
| 14 | 34517 | | Piston, Pin & Ring Set (Std.) (2-3/4" Bore) |
| 14 | 34518 | | Piston, Pin & Ring Set (.010" OS) |
| 14 | 34519 | | Piston, Pin & Ring Set (.020" OS) |
| 15 | 32595 | | Ring Set (Std.) (2-3/4" Bore) |
| 15 | 32596 | | Ring Set (.010" OS) |
| 15 | 32597 | | Ring Set (.020" OS) |
| 16 | 27888 | | Ring, Piston pin retaining |
| 17 | 32591C | | Rod Assy., Connecting (Incl. 10 & 18) |
| 18 | 650662C | | Screw, Connecting rod (2 each) |
| 19 | 32678 | | Nipple, Oil drain |
| 20 | 30969 | | Cap, Oil drain |
| 21 | 32115 | | Camshaft (MCR) |
| 22 | 34034 | | Lifter, Valve |
| 23 | 31303B | | Cover, Cylinder (Incl. 24, 106 & 279) |
| 24 | 28427 | | Seal, Oil |
| 24B | 31546 | | Bushing, Crankshaft (Use as required) |
| 25 | 31297 | | Dipstick, Oil (Incl. 30) |
| 26 | 30684 | | * Gasket, Cylinder cover |
| 28 | 650488 | | Screw, 1/4-20 x 1-1/4" |
| 30 | 29673 | | * Gasket, Oil filler |
| 31 | 650489 | | Screw, 1/4-20 x 5/8" |
| 32 | 32631A | | * Gasket, Cylinder head |
| 33 | 30938A | | Head, Cylinder |
| 34 | 27793 | | Clip, Conduit (Use as required) |
| 35 | 28942 | | Screw, 10-32 x 3/8" (Use as required) |
| 36 | 650697A | | Screw, 5/16-18 x 2-1/2" (Use as requi red) |
| 36 | 650695A | | Screw, 5/16-18 x 2-1/4" (Use as requi red) |
| 36 | 650694A | | Screw, 5/16-18 x 2" (Use as required) |

| Ref # | Part Number | Qty | Description |
|-------|-------------|-----|--|
| 37 | 33636 | | Resistor Spark Plug (RJ-8C) |
| 37 | 34251 | | Resistor Spark Plug |
| 38 | 27896A | | * Gasket, Breather cover |
| 39 | 28423 | | Body, Breather |
| 40 | 28424 | | Element, Breather |
| 41 | 28425 | | Cover, Valve spring |
| 42 | 26073 | | Washer (Use as required) |
| 42 | 650691 | | Washer, Flat (Use as required) |
| 42A | 650690 | | Washer, Belleville (Use as required) |
| 43 | 650128 | | Screw, 10-24 x 1/2" |
| 45 | 27915A | | * Gasket, Intake |
| 46 | 30195A | | Flange, Carburetor (Incl. 79 & 80) |
| 47 | 30196 | | Screw, 5/16-18 x 3/4" |
| 48 | 29716 | | Screw, 1/4-28 x 7/16" |
| 50 | 650548 | | Screw, 8-32 x 5/16" |
| 52 | 32326A | | Lever, Governor (New lever does not need 1 of 51,66,132,164,165,207) |
| 55 | 30205 | | Bracket, Adjusting |
| 56 | 30824 | | Link, Throttle |
| 59 | 29216 | | Nut, Lock, 10-32 |
| 61 | 29826 | | Screw, 10-32 x 3/4" |
| 62 | 29642 | | Ring, Retaining |
| 63A | 30699C | | Rod Assy., Governor (Incl. 64 & 65) |
| 63 | 30699B | | Governor Rod Ass'y. (This one-piece governor rod is no longer used. It is replaced by 30699C ass'y., Ref. no. 63A) |
| 64 | 30700 | | Yoke, Governor |
| 65 | 650494 | | Screw, 6-40 x 5/16" |
| 66 | 29918 | | Lockwasher, #8 E.T. |
| 67 | 35350 | | Tube, Breather |
| 69 | 29747B | | Screw, 5/16-24 x 21/32" |
| 70 | 32158E | | Blower Housing (For elec.star.)(Incl. 134,135) |
| 71 | 650815 | | Washer, Belleville |
| 72 | 8116 | | Nut, Hex |
| 73 | 29536 | | Blower Housing Baffle (without electric starter knock-out) (Use as required) |
| 73 | 35256A | | Blower Housing Baffle (with electric starter knock-out) (Use as required) (Point Ignition) |
| 74 | 650561 | | Screw, 1/4-20 x 5/8" |
| 75 | 31688A | | * Gasket, Carburetor |
| 79 | 29752 | | Nut & Lockwasher Assy., 1/4-28 |
| 80 | 650572 | | Screw, 1/4-28 x 1-1/8" |
| 82A | 730164 | | Air Cleaner Ass'y. (Incl. 60, 83, 87, 88, 89, 90A & 331B) (Use as required) |
| 97 | 34131 | | Ground Wire |
| 100 | 29538 | | Base, Engine mounting |
| 103 | 32401 | | Muffler |
| 106 | 31845 | | Shaft, Mechanical governor |
| 107 | 30591 | | Gear Assy., Governor (Incl. 109) |
| 108 | 30588A | | Spool, Governor |
| 109 | 30590A | | Washer, Flat |
| 110 | 29193 | | Ring, Retaining |
| 111C | 34158 | | Bracket, Fuel tank |

| Ref # | Part Number | Qty | Description |
|-------|-------------|-----|--|
| 113 | 650561 | | Screw, 1/4-20 x 5/8" |
| 114 | 34156A | | Fuel Tank (Incl. 115 & 266) NOTE: These tanks were built with different size fuel inlet openings. Tanks with the 1-3/16" I.D. opening use fuel cap 33032 or 34210. Tanks with the 1-1/2" I.D. opening use fuel cap 35355 or 35650. |
| 115 | 410144B | | Fuel Cap (White Plastic)(Std)(As required) |
| 115 | 33032 | | Fuel Cap (Charcoal Plastic) (Spurt resistant, Low profile) (Use as required) |
| 115 | 34210 | | Fuel Cap (Red Plastic) (Spurt resistant, High profile) (Use as required) |
| 115 | 35355 | | Fuel Cap (Use as required) |
| 116D | 34159 | | Plate, Fuel tank mounting |
| 118 | 29774 | | Fuel Line (Braided 8-1/4" 21 cm)(Use as req.) |
| 118 | 30705 | | Fuel Line (Braided 16") (41 cm) (Use as req.) |
| 118 | 30962 | | Fuel Line (Braided 32") (81 cm) (Use as req.) |
| 120 | 650128 | | Screw, 10-24 x 1/2" (Use as required) |
| 121 | 30622A | | Extension, Blower housing |
| 124 | 650542 | | Screw, 5/16-18 x 3/4" |
| 125 | 27930A | | Gasket, Exhaust |
| 126 | 30196 | | Screw, 5/16-18 x 3/4" |
| 127 | 26073 | | Washer (Use as required) |
| 128 | 650694A | | Screw, 5/16-18 x 2" (Use as required) |
| 129 | 32589 | | Key, Flywheel |
| 130 | 31843A | | Bracket, Governor gear |
| 131 | 650836 | | Screw, 10-24 x 1/2" |
| 133 | 650493 | | Screw, 1/4-20 x 1-3/4" |
| 149 | 30747 | | Clip, Shorting |
| 151 | 650665 | | Screw, 1/4-15 x 7/8" |
| 193 | 610118 | | Cover, Spark plug (Use as required) |
| 205 | 650561 | | Screw, 1/4-20 x 5/8" (Use as required) |
| 209 | 30939A | | Cover, Cylinder head |
| 223 | 32180C | | Line, Primer |
| 225 | 34126 | | Bracket, Grommet mounting |
| 226 | 650760 | | Screw, 8-32 x 3/8" |
| 227 | 28545 | | Grommet |
| 246 | 32125 | | Cup, Starter |
| 247 | 590417 | | Screen, Starter cup |
| 266 | 26460 | | Clamp, Fuel line |
| 270 | 31461 | | Bushing, Crankshaft (Use as required) |
| 274 | 610973 | | Terminal Ass'y. (As req. on late production) |
| 287 | 27275 | | Clip, Hi-tension wire (Use as required) |
| 287 | 34246 | | Clip, Ground wire (Use as required) |
| 331 | 34170 | | Decal, Instruction |
| 331A | 34346 | | Decal, Instruction |
| 332 | 30547A | | Contact Assy., Breaker |
| 333 | 30548B | | Condenser |
| 334 | 631021 | | Inlet Needle, Seat & Clip Assy. |
| 336 | 631920 | | Carburetor (Incl. 75) (Refer to Division 5, Section A, page 138 for breakdown) |

| Ref # | Part Number | Qty | Description |
|-------|-------------|-----|---|
| 337 | 610694A | | Magneto (w/ring gear for 110 volt starter) NOTE: The complete magneto is not available as an assembly. The magneto number is shown for reference purposes only. Order component parts individually, as show in parts list. (Refer to Division 5, Section B, page 24 for breakdown) |
| 338 | 590473 | | Rewind Starter (Refer to Division 5, Section C, page 29 for breakdown) |
| 343 | 33239A | | Gasket Set (Incl. items marked*) |

ILLUSTRATION SHOWS TYPICAL PARTS ONLY. ORDER BY PART NUMBER. PARTS NOT LISTED ARE SUPPLIED BY OEM.

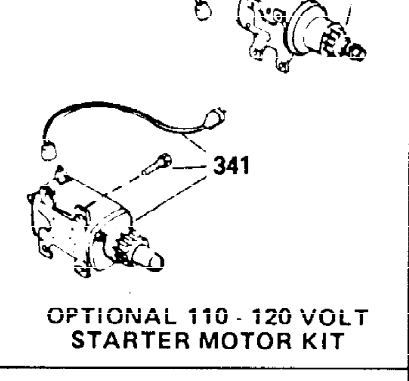
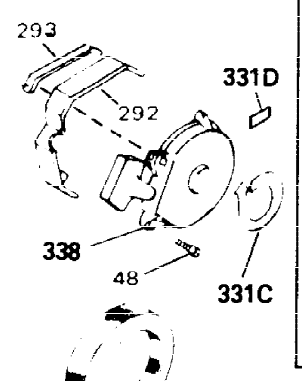
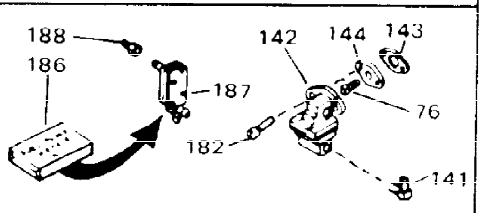
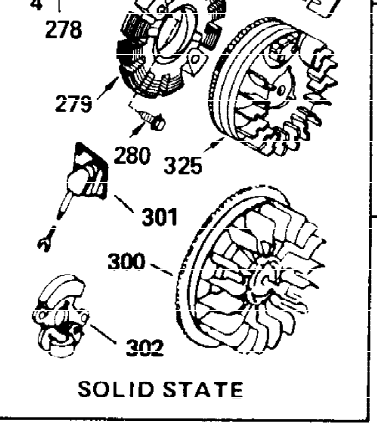
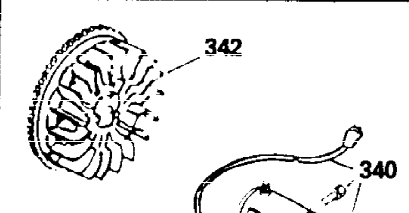
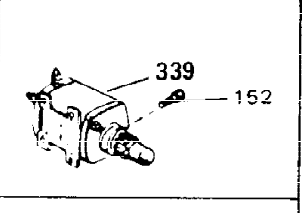
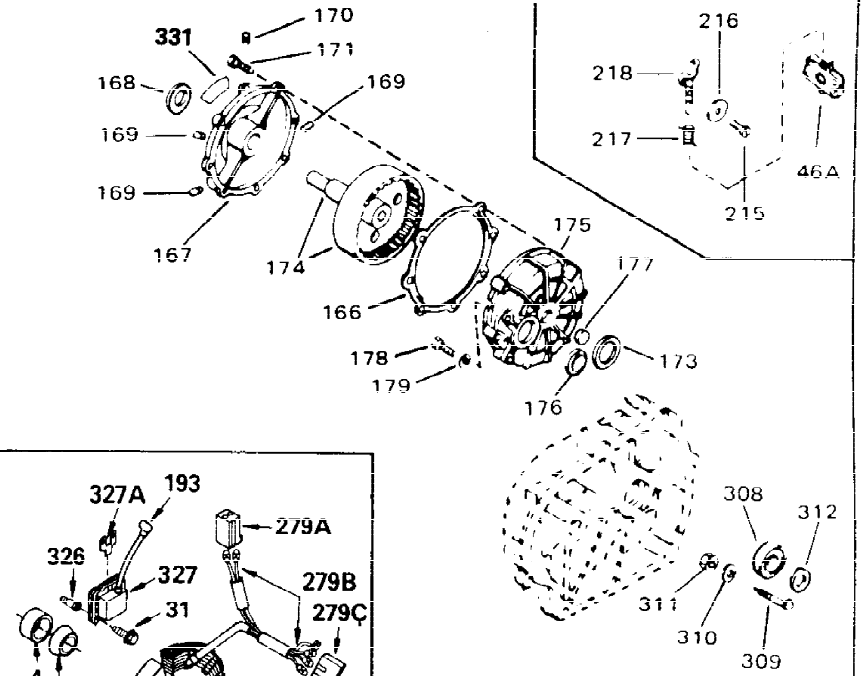
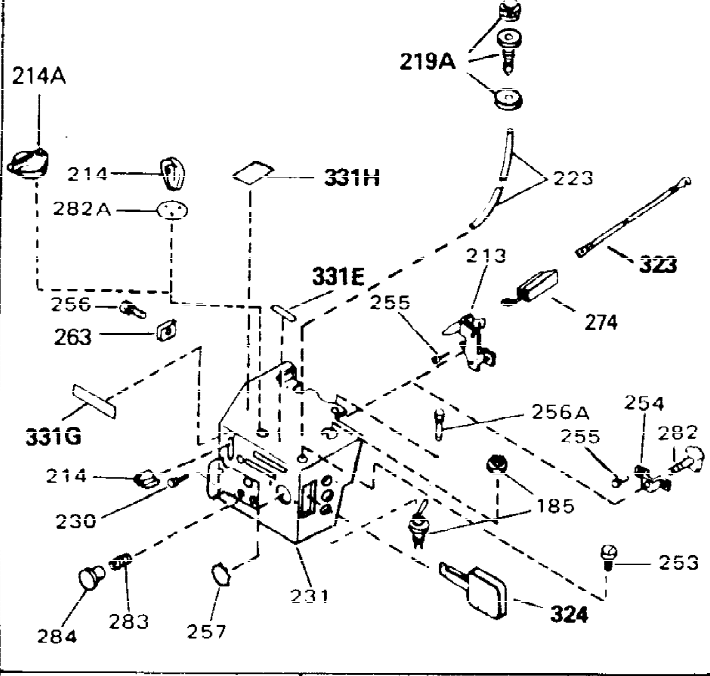

SOLID STATE

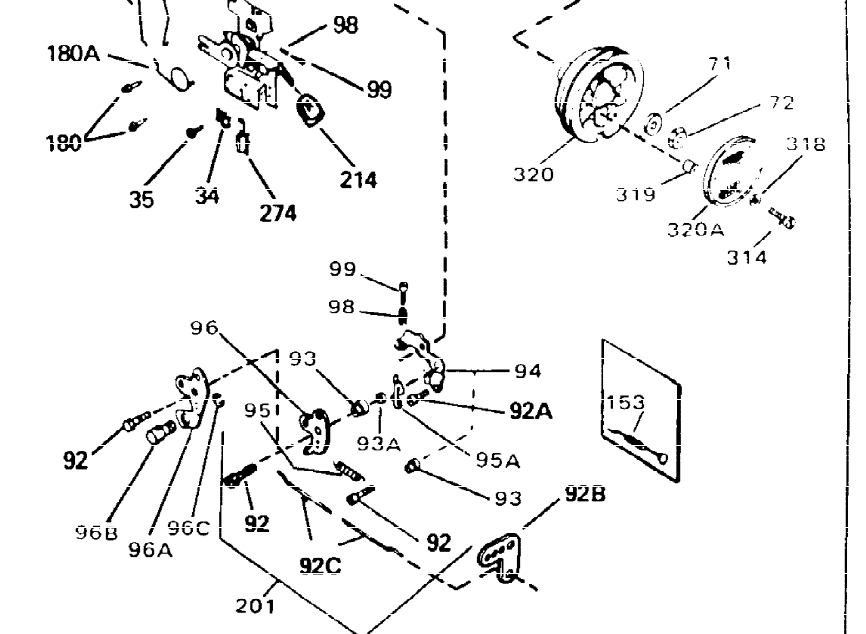
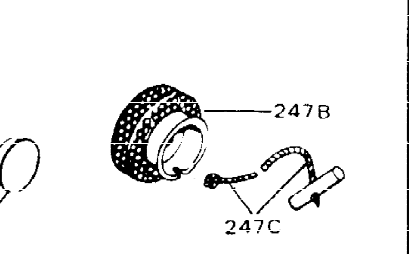
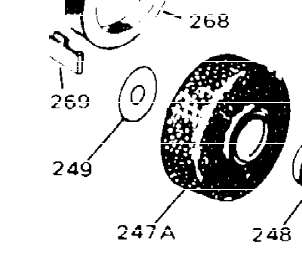
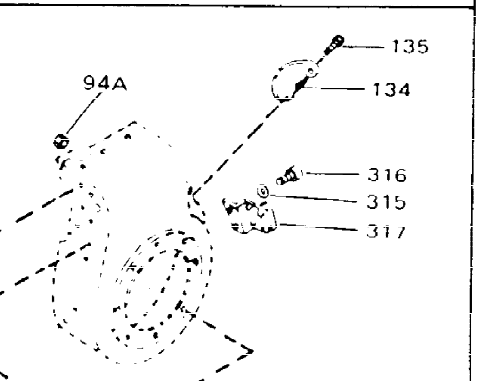

| Ref # | Part Number | Qty | Description |
|-------|-------------|-----|---|
| 31 | 650489 | | Screw, 1/4-20 x 5/8" |
| 34 | 27793 | | Clip, Conduit (Use as required) |
| 35 | 28942 | | Screw, 10-32 x 3/8" (Use as required) |
| 43A | 650128 | | Screw, 10-24 x 1/2" |
| 48 | 29716 | | Screw, 1/4-28 x 7/16" |
| 56 | 30824 | | Link, Throttle |
| 71 | 650815 | | Washer, Belleville |
| 72 | 8116 | | Nut, Hex |
| 134 | 33013 | | Cover, Bubble |
| 135 | 650736 | | Screw, 10-16 x 3/8" |
| 193 | 610118 | | Cover, Spark plug (Use as required) |
| 200 | 33108A | | Control Bracket (Incl. 224 & 274) |
| 214 | 32410 | | Knob, Speed control |
| 219A | 570629A | | Primer Assy. |
| 223 | 32180C | | Line, Primer |
| 224 | 30826 | | Spring, Extension |
| 230 | 650257 | | Screw, 8-32 x 5/16" |
| 231 | 34217 | | Cover, Carburetor |
| 254 | 32398 | | Bracket, Choke |
| 255 | 28820 | | Screw, 10-32 x 1/2" |
| 256A | 650765 | | Screw, 10-32 x 1/2" |
| 256 | 650760 | | Screw, 8-32 x 3/8" |
| 257 | 31291 | | Plug, Cover |
| 263 | 650764 | | Nut, "U" Type (Use as required) |
| 274 | 610973 | | Terminal Ass'y. (As req. on late production) |
| 282A | 34132 | | Plate, Choke indicator |
| 292 | 34127 | | Guard Starter |
| 293 | 32576 | | Seal, Snow guard |
| 331 | 34170 | | Decal, Instruction |
| 331G | 34416 | | Decal, Choke |
| 331E | 34144 | | Decal, Primer |
| 331H | 34414 | | Decal, Warning |
| 338 | 590473 | | Rewind Starter (Refer to Division 5, Section C, page 29 for breakdown) |
| 340 | 33328D | | Starter Motor Kit (110-120 Volt) This 110-120 volt starter motor kit may have been added to this engine. It can be added only if cylinder has drilled and tapped starter mounting bosses and a ring gear flywheel (see#342). Refer to service number stamped on end cap of motor, or on decal, for identification |
| 342 | 30811A | | Flywheel (Ring gear flywheel required on engines using 110-120 volt starter kits listed above) |
| 342 | 611042 | | Flywheel (Used on Type letters H and above) (Std. Point ignition) (Ring gear flywheel required on engines using 110-120 volt starter kits listed above) |
| 342 | 611085 | | Flywheel (Minimum ring gear flywheel required on engines using 110-120 volt starter kits listed above) (Use with Solid State ignition) |

ILLUSTRATION SHOWS TYPICAL PARTS ONLY. ORDER BY PART NUMBER. PARTS NOT LISTED ARE SUPPLIED BY OEM.



| Ref # | Part Number | Qty | Description |
|-------|-------------|-----|--|
| 27 | 27513 | | Lockwasher, 1/4" (Use as required) |
| 36 | 650697A | | Screw, 5/16-18 x 2-1/2" (Use as required) |
| 36 | 650695A | | Screw, 5/16-18 x 2-1/4" (Use as required) |
| 36 | 650694A | | Screw, 5/16-18 x 2" (Use as required) |
| 38 | 27896A | | * Gasket, Breather cover |
| 42 | 26073 | | Washer (Use as required) |
| 42 | 650691 | | Washer, Flat (Use as required) |
| 50 | 650548 | | Screw, 8-32 x 5/16" |
| 51 | 30319 | | Rivet, Split (Used in early production) |
| 52 | 32326A | | Lever, Governor (New lever does not need 1 of 51,66,132,164,165,207) |
| 55 | 30205 | | Bracket, Adjusting |
| 57 | 730130 | | Exh.Adap.Kit (Incl. 58 & 125) (Use as req.) |
| 58 | 30196 | | Screw, 5/16-18 x 3/4" (Use as required) |
| 59 | 29216 | | Nut, Lock, 10-32 |
| 61 | 29826 | | Screw, 10-32 x 3/4" |
| 66 | 29918 | | Lockwasher, #8 E.T. |
| 82B | 730561 | | Air cleaner kit (Incl. 38, 67A, 83, 84B, 85,89B, 89C, 90A, 91, 91A, 91B, 91C, 91D, 245 & 331B) (Use only on engines with an externally vented fully adjustable carburetor) |
| 82 | 730127 | | Air Cleaner Ass'y. (Incl. 60, 83, 87, 88, 89A, 90, 238 & 331B) (Use as required) |
| 84D | 34819 | | Air Cleaner Elbow (Incl. 84B, 86A, 91, 91A, 91B & 91C) (Use in 730561 assembly only) NOTE: 130010 thru 10C & 11 used in early production only. |
| 103E | 391026 | | Opt. Spark Arrest Muffler (Incl.196,1 97,199) |
| 113 | 650561 | | Screw, 1/4-20 x 5/8" |
| 118 | 29774 | | Fuel Line (Braided 8-1/4" 21 cm)(Use as req.) |
| 118 | 30705 | | Fuel Line (Braided 16") (41 cm) (Use as req.) |
| 118 | 30962 | | Fuel Line (Braided 32") (81 cm) (Use as req.) |
| 125 | 27930A | | Gasket, Exhaust |
| 126 | 30196 | | Screw, 5/16-18 x 3/4" |
| 128 | 650694A | | Screw, 5/16-18 x 2" (Use as required) |
| 132 | 650548 | | Screw, 8-32 x 5/16" (Early production) |
| 148 | 34067 | | Wire Assy., Alternator adapter (4-1/4 ") |
| 148 | 34069 | | Wire Assy., Alternator adapter (6-3/4 ") |
| 202 | 31288 | | Exh. Adaptor Kit (Incl.125,203,204) (As req.) |
| 203 | 650697A | | Screw, 5/16-18 x 2-1/2" (Use as required) |
| 204 | 6021A | | Screw, 5/16-18 x 1-1/2" (Use as required) |
| 226 | 650760 | | Screw, 8-32 x 3/8" |
| 227 | 28545 | | Grommet |
| 266 | 26460 | | Clamp, Fuel line |