

SECTION 12: MODEL 689 PARTS LIST

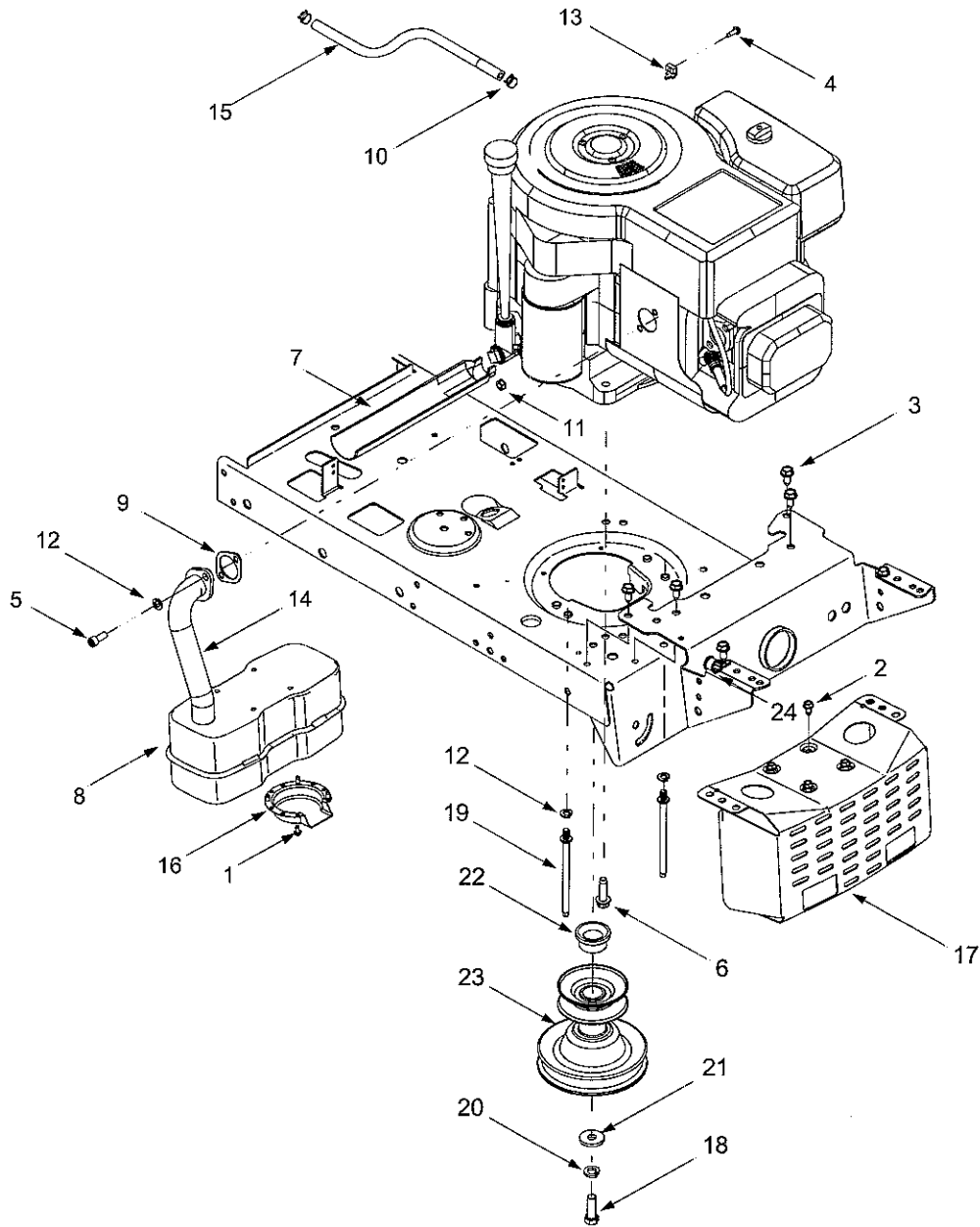

REF. NO.	PART NO.	DESCRIPTION	REF. NO.	PART NO.	DESCRIPTION
1	710-0148	Screw, #8-32 x .375	13	751B213146	Casing Clamp
2	710-0599	Self-tapping Screw, 1/4-20 x .5	14	751-0619A	Exhaust Pipe
3	710-0726	Self-tapping Screw, 5/16-12 x .75	15	751-0535	Fuel Line Hose
4	710-1237	Screw, #10-32 x .625	16	751-0564A	Muffler Deflector
5	710-1314A	Socket Cap Screw, 5/16-18 x .625	17	783-0615C	Muffler Heat Shield
6	710-1315	Self-tapping Screw, 3/8-16 x 1.25	18	710-3029	Hex Screw, 7/16-20 x 1.25
7	731-1682A	Oil Drain Sleeve	19	711-1044	Belt Keeper Pin, 5/16 x 4.75
8	751-0617A	Muffler, Single Inlet	20	736-0171	Lock Washer, 7/16
9	721-0208	Exhaust Gasket	21	736-0322	Flat Washer, .450 x 1.25 x .164
10	726-0205	Hose Clamp, .490	22	750-0956	Spacer, 1 0 x 1.4 x .825
11	712-0271	Hex Sems Nut, 1/4-20	23	756-04023	Engine Pulley, 3.12 x 5.56
12	736-0119	Lock Washer, 5/16	24	726-0272	Clamp

Model 689

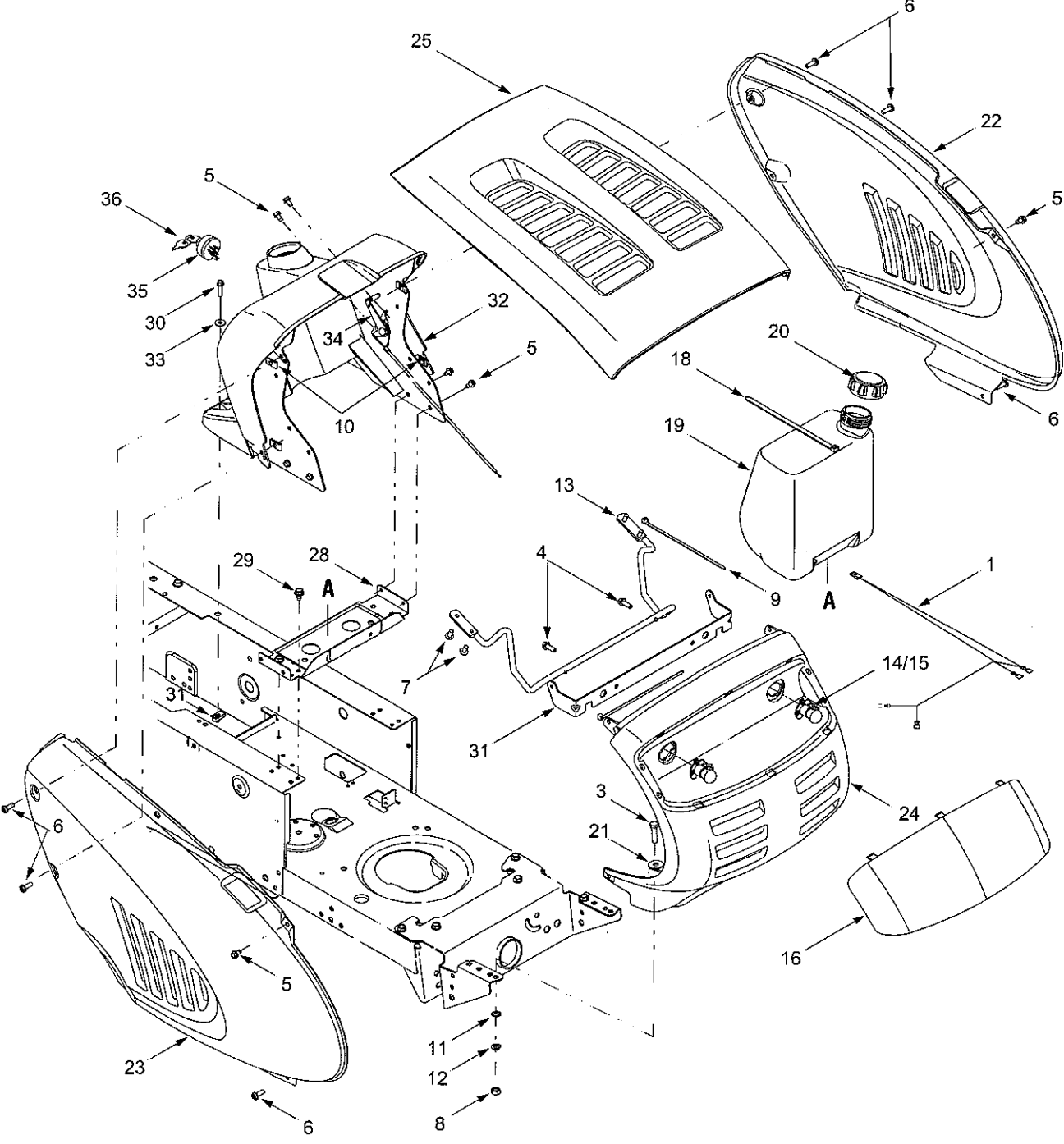

Model 689

REF. NO.	PART NO.	DESCRIPTION
1	629-0469B	Headlamp Harness Assembly
2	683-0195	Bracket Assembly
3	710-0528	Hex Screw, 5/16-18 x 1.50
4	710-0895	Self-tapping Screw, 1/4-15 x .75
5	710-0599	Self-tapping Screw, 1/4-20 x .5
6	710-0924	Machine Screw, 1/4-20 x .75
7	710-1017	Screw, 1/4-20 x .625
8	712-3010	Hex Nut, 5/16-18
9	725-0157	Cable Tie, 7.4"
10	712-0292	U-type Speed Nut
11	726-0201	Speed Nut, 5/16
12	736-0119	Lock Washer, 5/16
13	747-2138	Hinge Rod
14	725-0963	Headlamp, 12V
15	725-1649	Headlamp Socket
16	731-2637	Headlight Lens
17	735-0126	Rubber Washer, .87 x .33
18	726-0230	Cable Tie, 30.66
19	751-0555B	Fuel Tank, 1.5 gal.
20	751-0603	Fuel Tank Cap
21	736-3078	Flat Washer, .344 x 1.0 x .063
22	783-0785	LH Side Panel
23	783-0784	RH Side Panel
24	731-2119A	Grille
25	783-0783	Hood
26	783-0553A	Hood Support Bracket
27	783-1495	Hood Side Bracket
28	17632D	Battery Support Bracket
29	710-0607	Self-tapping Screw, 5/16-18 x .5
30	710-0788	Self-tapping Screw, 1/4-20 x 1.0
31	783-1346	Grille Support Bracket
32	731-04180	Dash Panel
33	736-3090	Flat Washer, .260 x .720 x .060
34	746-04020A	Throttle / Choke Control, 18.5"
35	725-1396	Ignition Switch, 6-pin
36	725-0201	Keys (pair)
—	777X40137	Headlight Lens Reflector (not shown)

NOTE: Tractor features vary by model. NOT all parts listed above and pictured on the previous page are standard equipment.

Model 689

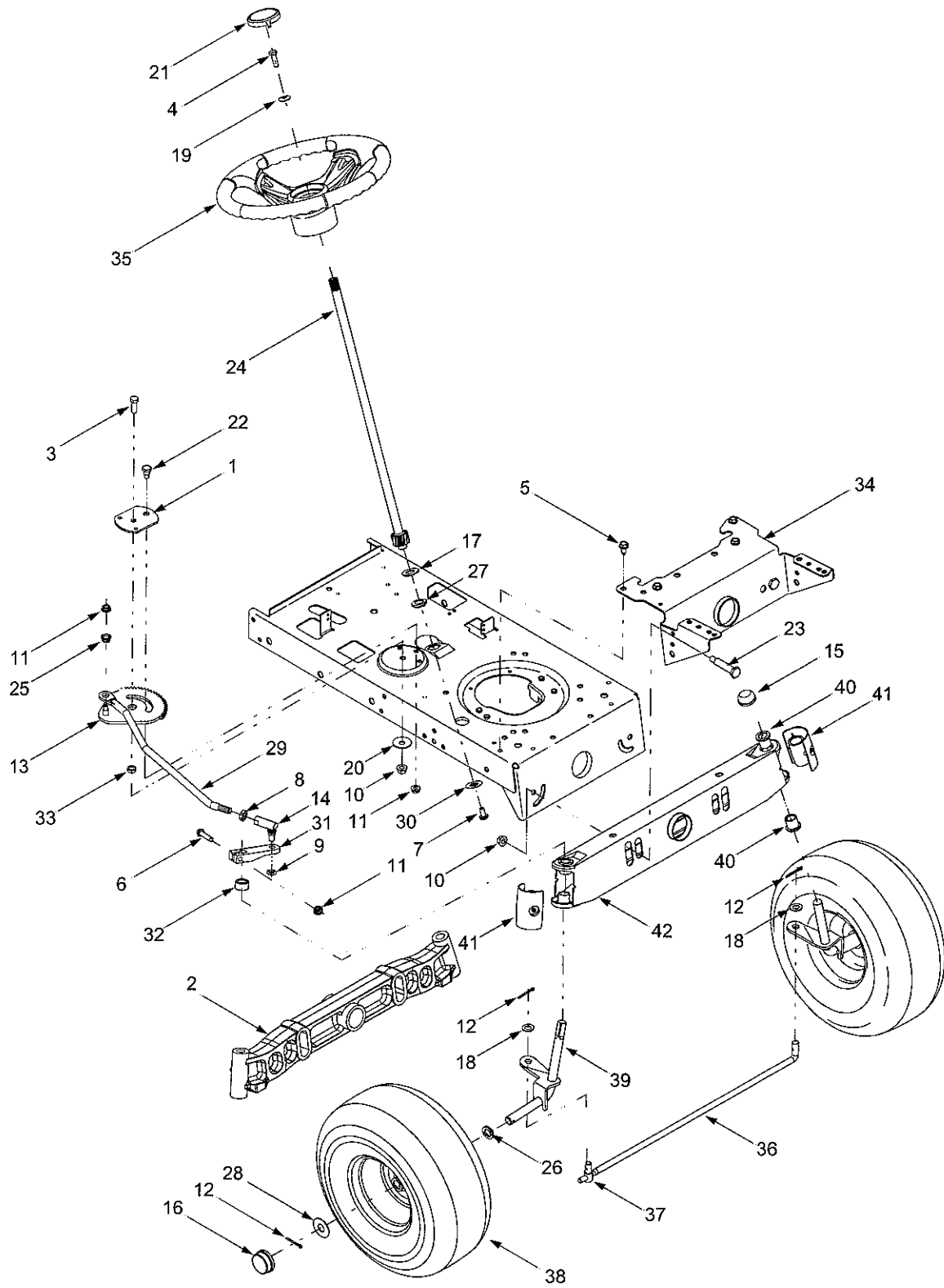

Models 698

REF. NO.	PART NO.	DESCRIPTION
1	17198A	Retainer Gear Segment Plate
2	719-0399B	Cast Iron Pivot Bar, .625
3	710-0514	Hex Cap Screw, 3/8-16 x 1.0
4	710-0643	Hex Cap Screw, 5/16-18 x 1.0
5	710-0726	Self-tapping Screw, 5/16-12 x .75
6	710-0805	Hex Cap Screw, 5/16-18 x 1.5
7	710-1309	Machine Screw, 5/16-18 x .75
8	712-0240	Jam Nut, 7/16-20 (Grade 2)
9	712-0262	Jam Nut, 3/8-24
10	712-0431	Flange Lock Nut, 3/8-16
11	712-3004A	Flange Lock Nut, 5/16-18
12	714-0470	Cotter Pin, 1/8 x 1.25
13	717-1757A	Steering Segment Gear
14	723-0448A	Ball Joint, 7/16 -20
15	726-0214	Push Cap, .625
16	731-0484A	Hub Cap
17	736-0187	Flat Washer, .64 x 1.24 x .060
18	736-0226	Flat Washer, .474 x .879 x .064
19	736-0242	Bell Washer, .34 x .872 x .060
20	736-0356	Bell Washer, .391 x .380 x .062
21	731-04681	Steering Wheel Cap, Small, Troy-Bilt
22	738-0141	Shoulder Screw, .435 x .350, 5/16-18
23	738-0527	Shoulder Screw, .498 x 2.045
24	738-0919	Steering Shaft, 21.86
25	741-0475	Plastic Bushing, .38 ID
26	736-0162	Flat Washer, .64 x 1.0 x .12
27	741-0656	Hex Flange Bearing, 5/8
28	736-0285	Flat Washer, .635 x 1.589 x .06
29	747-1268B	Steering Drag Link, 7/16-20
30	748-0389	Cap, 1.25 x .16
31	748-04014A	Steering Arm
32	748-04020	Spacer, 1.0 x .645 x .56
33	750-0535	Spacer, .380 x .625 x .21
34	783-0041D	Pivot Bar Bracket
35	631-04008	Steering Wheel, Three Spoke
36	747-04057	Tie Rod, Adjustable
37	711-04059	Ferrule, 3/8-24 x .437 Dia
38	634-0105A	Square Shoulder Wheel Ass'y Complete
39	683-04016	RH Axle Assembly
	683-04015	LH Axle Assembly
40	741-0487A	Flange Bearing
41	731-0405B	End Cap w/ Fitting
42	683-0002A	Steel Pivot Bar, .625

	Wheel Ass'y Complete	Rim Assembly	Inner Bearing	Outer Bearing	Tire Only	Air Valve
Square Shoulder	634-0105A	634-0172	741-0706 (Flange w/ Fitting)	741-0487A (Plastic Flange)	734-1731 (15 x 6 x 6)	734-0255

NOTE: Tractor features vary by model. NOT all parts listed above and pictured on the previous page are standard equipment

Model 689

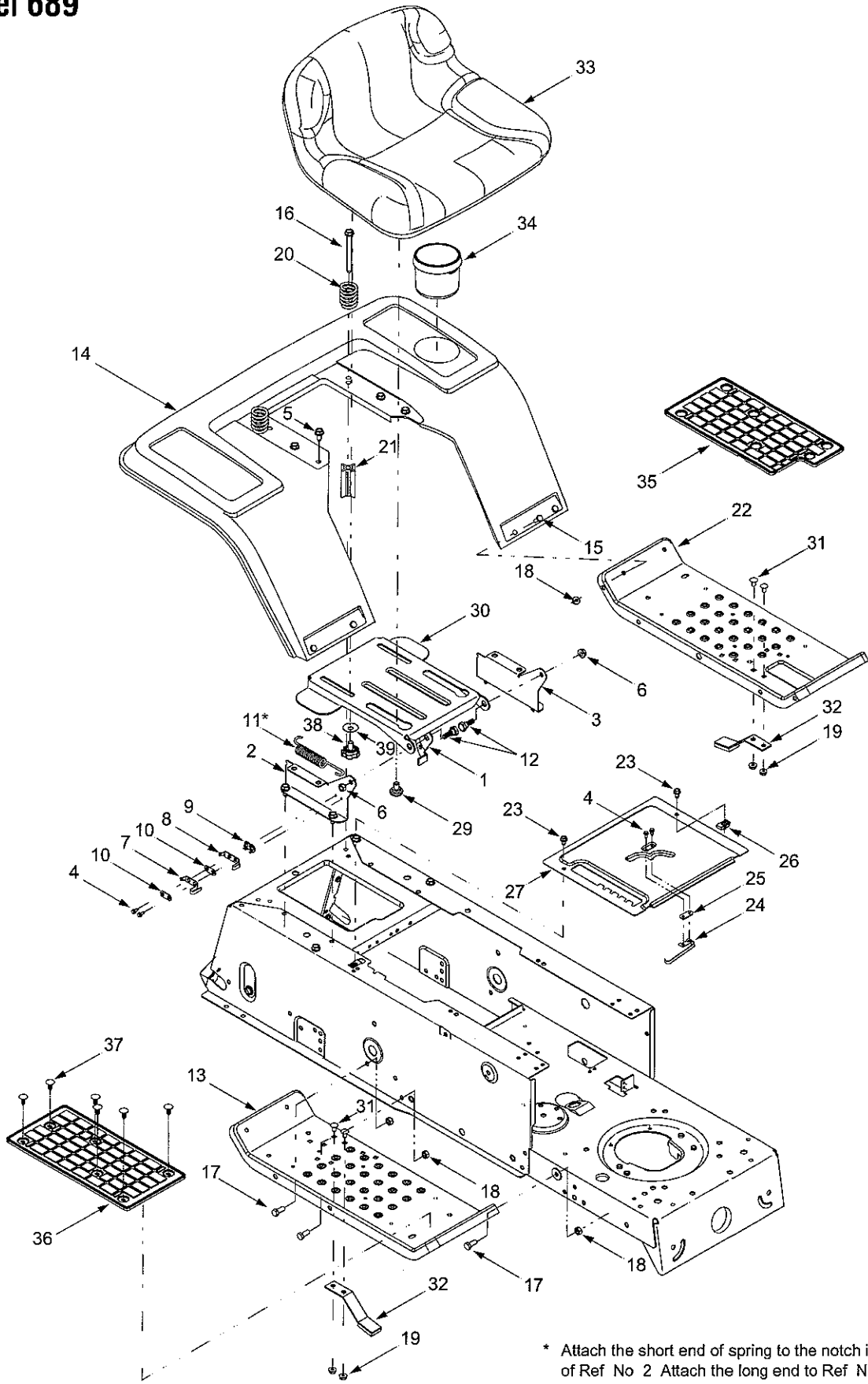

* Attach the short end of spring to the notch in the rear of Ref No 2 Attach the long end to Ref No. 1

Model 689

REF. NO.	PART NO.	DESCRIPTION
1	17239C	Seat Lift Bracket
2	17950A	RH Pivot Support Bracket, Seat
3	17951A	LH Pivot Support Bracket, Seat
4	710-0227	Self-tapping Screw, #8-18 x .50
5	710-0726	Self-tapping Screw, 5/16-12 x .75
6	712-0429	Hex Lock Nut, 5/16-18
7	725-1303	Outer Seat Spring Switch
8	725-1439	Inner Seat Spring Switch
9	726-0278	Insulator Plate Boss
10	726-0279	Insulator Plate
11	732-0581B	Extension Spring, .75 x 5.31
12	738-0296	Shoulder Screw, .437 x .286
13	17770G	Running Board
14	17870C	Fender (models w/o cupholder)
	783-04474	Fender (models w/ cupholder)
15	710-0751	Hex Screw, 1/4-20 x .620
16	710-1208	Self-tapping Screw, 5/16-18 x 3.5
17	710-3008	Hex Screw, 5/16-18 x .75
18	712-0429	Nylon Lock Nut, 5/16-18
19	712-3027	Flange Lock Nut, 1/4-20
20	732-04038	Compression Spring, 1 3/4 x 1.8
21	750-04212	Spacer
22	783-04139	LH Running Board
23	710-0599	Self-tapping Screw, 1/4-20 x .5
24	725-1643	Spring Switch, Long
25	726-0320	Insulator Nut Plate
26	726-3054	U-Clip Nut, 1/4-20
27	783-04050A	Shift Cover Panel, 8-speed
28	710-0870	Screw, 3/8-16 x .625
29	738-04012	Shoulder Screw, .625 x .175, 3/8-16
30	783-04081A	Seat Pivot Bracket, Manual Adjust
31	710-0703	Carriage Screw, 1/4-20 x .75
32	761-0168B	Blade Spindle Brake Assembly
33	757-04021	Low Back Seat, Black
34	731-04591	Cup Holder
35	735-04009	LH Rubber Foot Pad
36	735-0196	RH Rubber Foot Pad
37	726-3046	Ratchet Clip, .250 Dia
38	720-04009	Knob, 3/8-16 X .625
39	736-0219	Bell Washer, .389 x 1.120 x .030

NOTE: Tractor features vary by model NOT all parts listed above and pictured on the previous page are standard equipment.

Model 689

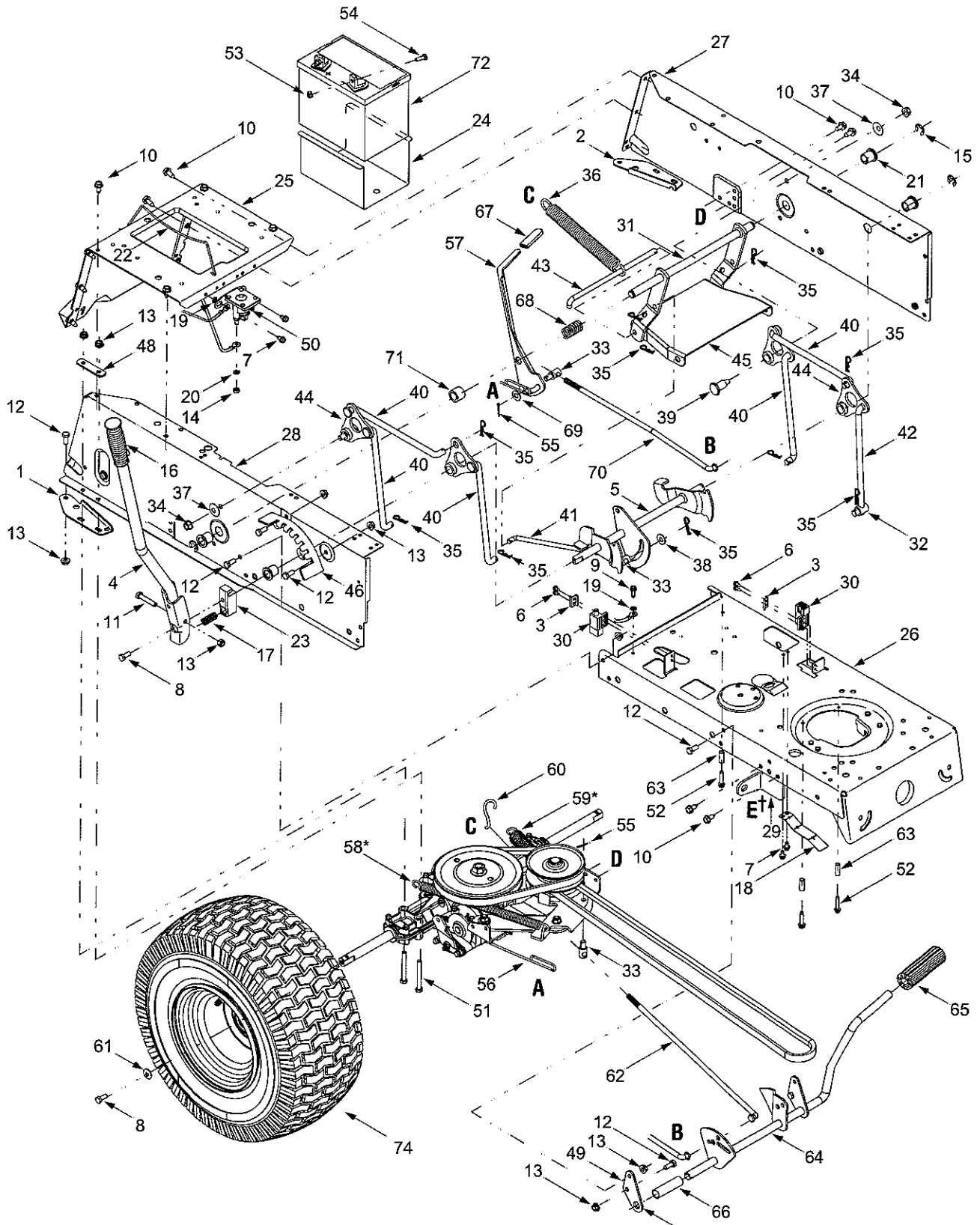

* Attach the ends of springs (Ref 58 & Ref 59) to the notch openings in the rear of Ref 25

† Refer to E† on Page 38

Model 689

REF. NO.	PART NO.	DESCRIPTION	REF. NO.	PART NO.	DESCRIPTION
1	17668A	RH Axle Support Bracket	38	736-0267	Flat Washer, .385 x .87 x .060
2	17669A	LH Axle Support Bracket	39	738-0322	Shoulder Bolt, .625 x .217
3	17962	Switch Plate	40	747-04018A	Deck Hanger Link
4	683-04025	Lift Handle Assembly	41	747-04040A	Deck Disengagement Rod
5	683-04049	Lift Shaft Assembly	42	747-04069A	Deck Hanger Link
6	710-0224	Self-tapping Screw, #10-16 x .5	43	747-04157	Rear Stabilizer Rod
7	710-0599	Self-tapping Screw, 1/4-20 x .5	44	748-04307	Lift Link
8	710-0627	Hex Cap Screw, 5/16-24 x .75	45	783-04294	Deck Stabilizer Bracket
9	710-0642	Self-tapping Screw, 1/4-20 x .75	46	783-04113	Deck Lift Index Bracket
10	710-0726	Self-tapping Screw, 5/16-12 x .75	47	17630A	Shift Lever Retainer
11	710-3180	Hex Cap Screw, 5/16-18 x 1.75	48	17840	Transaxle Mounting Bracket
12	710-3008	Hex Screw, 5/16-18 x .75	49	17860	Pedal Mounting Bracket
13	712-0429	Hex Lock Nut, 5/16-18	50	725-1426	Solenoid
14	712-3006	Hex Nut, 1/4-20	51	710-0176	Hex Cap Screw, 5/16-18 x 2.75
15	716-0106	E-Ring, .625 Dia Shaft	52	710-0809	Self-tapping Screw, 1/4-20 x 1.25
16	720-0233	Handle Grip	53	712-0271	Hex Sems Nut, 1/4-20
17	732-0369	Compression Spring, .55 x 1.37	54	710-3015	Hex Screw, 1/4-20 x .75
18	732-0750A	Switch Actuator Spring	55	714-0470	Cotter Pin
19	736-0222	External Lock Washer, 1/4	56	732-04029	Extension Spring, .59 x 12.38
20	736-0329	Lock Washer, 1/4	57	783-04059	Speed Select Lever
21	741-0487A	Flange Bearing, .632 ID	58	732-04075A	Extension Spring, .73 x 12.54
22	747-04031	Battery Hold-down Rod	59	732-04076	Extension Spring, 1.15 x 7.90
23	748-04011A	Lift Shaft Connector	60	732-0722A	Brake Return Spring
24	783-0345	Battery Tray	61	736-0242	Bell Washer, .34 x .872 x .060
25	783-0355D	Hitch Plate	62	747-04043	Variable Speed Control Rod
26	783-04011A	Lower Frame	63	750-0566A	Spacer, .260 x .372 x 1.030
27	783-04031	LH Upper Frame Side Panel	64	683-04005A	Clutch / Brake Pedal Assembly
28	783-04032	RH Upper Frame Side Panel	65	735-0196	Foot Pad, 4.6
29	783-04213	Deck Anti-sway Bracket	66	750-0802	Spacer, .640 x .76 x 2.63
30	725-04039	Screw-mount Interlock Switch	67	720-04008	Shift Handle Grip
31	683-04048	Stabilizer Shaft Assembly	68	732-04017	Compression Spring, .89 x 1.75
32	711-04036	Ferrule, 1/2-20 x .50	69	736-0300	Flat Washer, 406 x .875 x .059
33	711-04075A	Ferrule, 3/8-24 x .375	70	747-04039	Speed Control Rod
34	712-0130	Hex Lock Nut, 3/8-16	71	750-04080	Spacer, .640 x 1.0 x .78
35	714-04023	Internal Cotter Pin, .080 x 1.56	72	725-1737A	Battery, 190 CCA
36	732-04050A	Extension Spring, 1.07 x 9.52	73	712-3027	Flange Lock Nut, 1/4-20
37	736-0219	Bell Washer, .389 x 1.12 x .030	74	634-0104	Square Shoulder Wheel Ass'y Complete

	Wheel Assembly Complete	Rim Assembly	Tire Only	Air Valve
Square Shoulder	634-0104	634-0070	734-1730 (20 x 8 x 8)	734-0255

NOTE: Tractor features vary by model. NOT all parts listed above and pictured on the previous page are standard equipment

Model 689

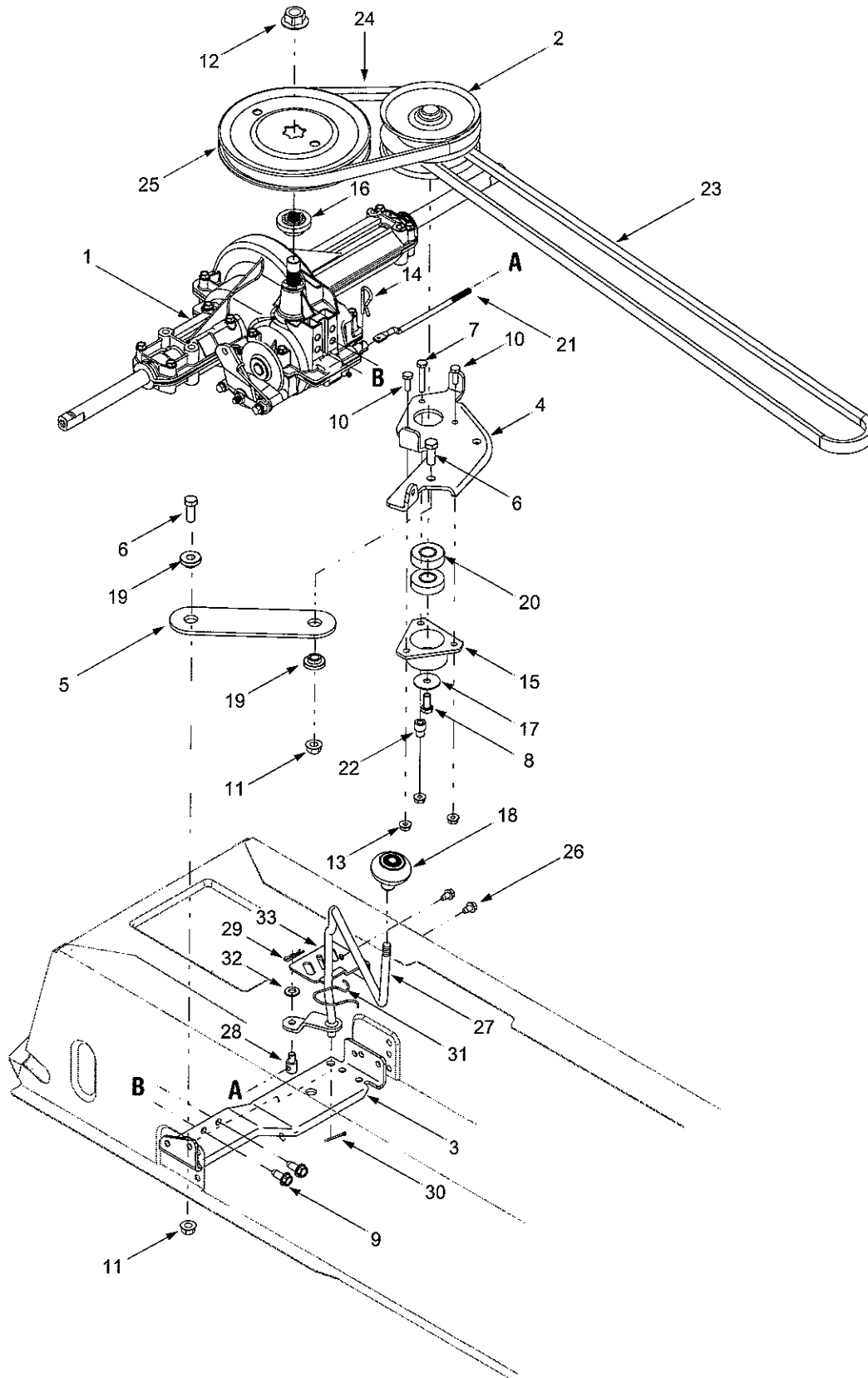

Model 689

REF. NO.	PART NO.	DESCRIPTION
1	618-04034	Transmission, Single-speed
2	656-0059A	Variable-speed Pulley, 4.75
3	683-04055	Torque Bracket
4	683-04056	Variable-speed Bracket
5	683-04057	Variable-speed Bracket
6	710-0514	Hex Cap Screw, 3/8-16 x 1.0
7	710-0606	Hex Cap Screw, 1/4-20 x 1.5
8	710-0627	Hex Cap Screw, 5/16-24 x .75
9	710-1260A	Screw, 5/16-18 x .75
10	710-3015	Hex Screw, 1/4-20 x .75
11	712-0431	Flange Lock Nut, 3/8-16
12	712-0700	Flange Nut, 9/16-18
13	712-3027	Flange Lock Nut, 1/4-20
14	714-0209	Internal Cotter Pin, .125
15	718-04012	Bearing Cup
16	718-0758A	Pulley Hub, 5/8 Spline
17	736-0362	Flat Washer, .320 x 1.25 x .06
18	720-04028	Shift Knob
19	738-0372B	Shoulder Spacer, 1.0 x .38 x .38
20	741-0600	Ball Bearing, 17 x 40 x 12
21	747-04072	Shift Rod
22	750-04099	Stepped Spacer
23	754-04001A	Lower Drive Belt
24	754-04002	Upper Drive Belt
25	756-04002	Transmission Pulley, 7.25
26	710-0599	Self-tapping Screw, 1/4-20 x .5
27	647-04019	Shift Lever Assembly
28	711-0736	Ferrule, 1/4-20 x 1.0
29	714-0104	Cotter Pin, 1.13
30	714-0470	Cotter Pin, 1.25
31	732-04067	Spring Compression Clip
32	736-0275	Flat Washer, .344 x .688 x .065
33	17630A	Shift Lever Retainer

NOTE: Tractor features vary by model. NOT all parts listed above and pictured on the previous page are standard equipment.

Model 689

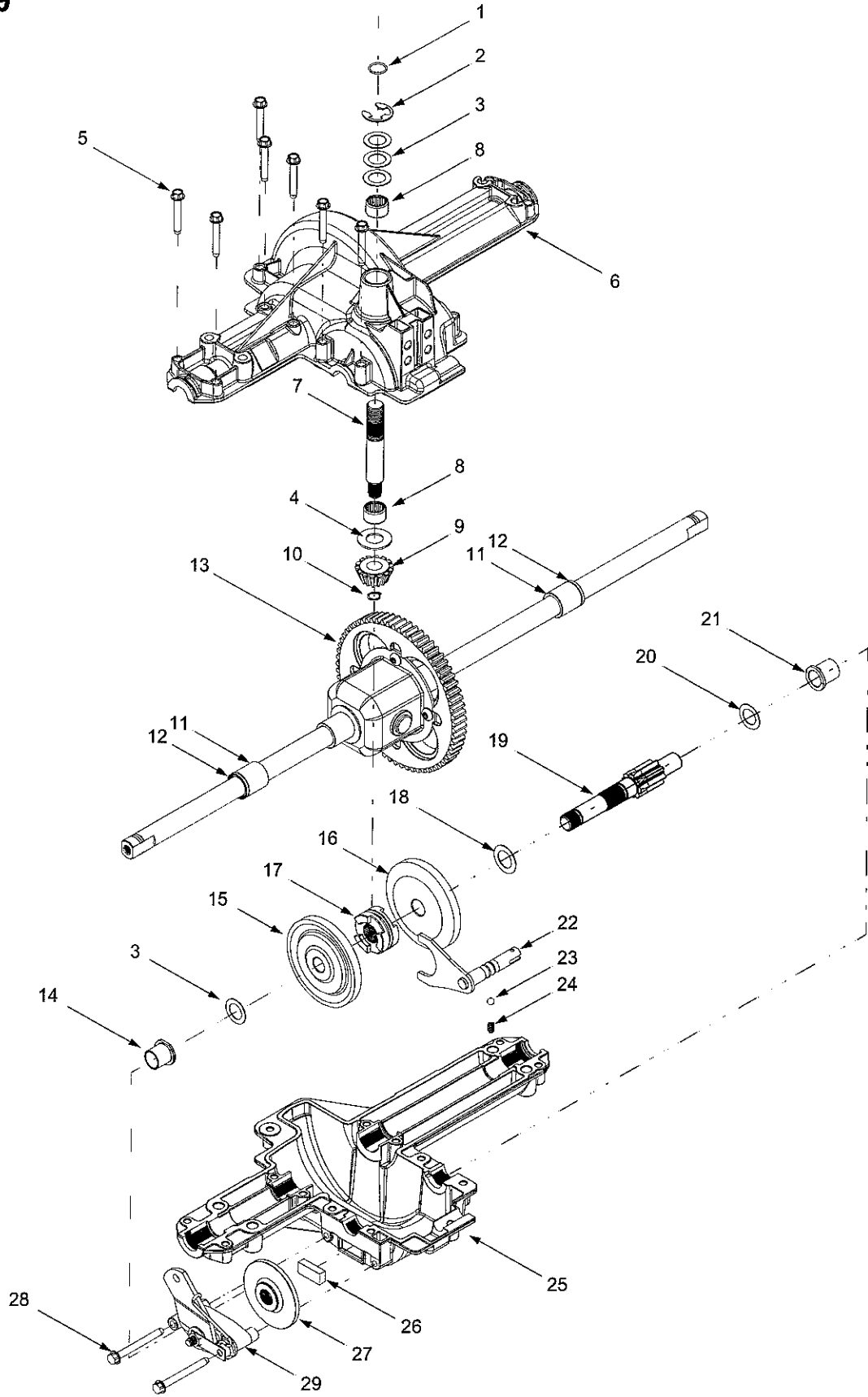

Model 689

REF. NO.	PART NO.	DESCRIPTION
1	732-0614	Ring, Wire
2	716-0231	Ring, E Type, .750
3	736-0336	Flat Washer, 5/8 x 1.0 x .030*
	736-0337	Flat Washer, 5/8 x 1.0 x .040*
	736-0349	Flat Washer, 5/8 x 1.0 x .020*
4	736-0335	Washer, Thrust .635 x 1.26 x .06
5	710-1325	Self-tapping Screw, 1/4-20 x 1.625
6	719-04017	Upper Housing
7	711-1109	Input Shaft
8	741-0335	Needle Bearing, .625 x .813 x .495
9	717-1464	14-tooth Bevel Pinion
10	716-0108	Retaining Ring, .437
11	741-0340	Sleeve Bearing, .75 x 1.0 x 1.0
12	721-0338	Seal, .75 x 1.0 x .125
13	618-04041	Differential Assembly
14	741-0336	Flange Bearing, 5/8 x 3/4 x 3/4
15	717-1362	42-tooth Bevel Gear
16	717-1363	42-tooth Bevel Gear
17	718-0228	Clutch Collar
18	736-0519	Flat Washer, .70 x 1.125 x .031
19	711-04053	Drive Shaft
20	736-0495	Thrust Washer, 1.0 x .632 x .0
21	741-0337	Flange Bearing, 5/8 x 3/4 x 15/16
22	611-0011	Detent Shaft Assembly
23	741-0862	Detent Ball
24	732-0863	Compression Spring
25	719-04018	Lower Housing
26	717-0678	Brake Puck
27	761-0202	Brake Disc
28	710-1206	Self-tapping Screw, 1/4-20 x 2.375
29	661-0001	Brake Assembly
—	737-0148	Grease (19 oz.)

*Use applicable flat washer (12a, 12b or 12c) in this application allowing .0150/.0020 in. end-play

NOTE: If rebuilding the upper housing, include two ounces (2 oz.) of Unirex[®] N3 grease (Part No. 737-0289) in the input shaft cavity.

Model 689

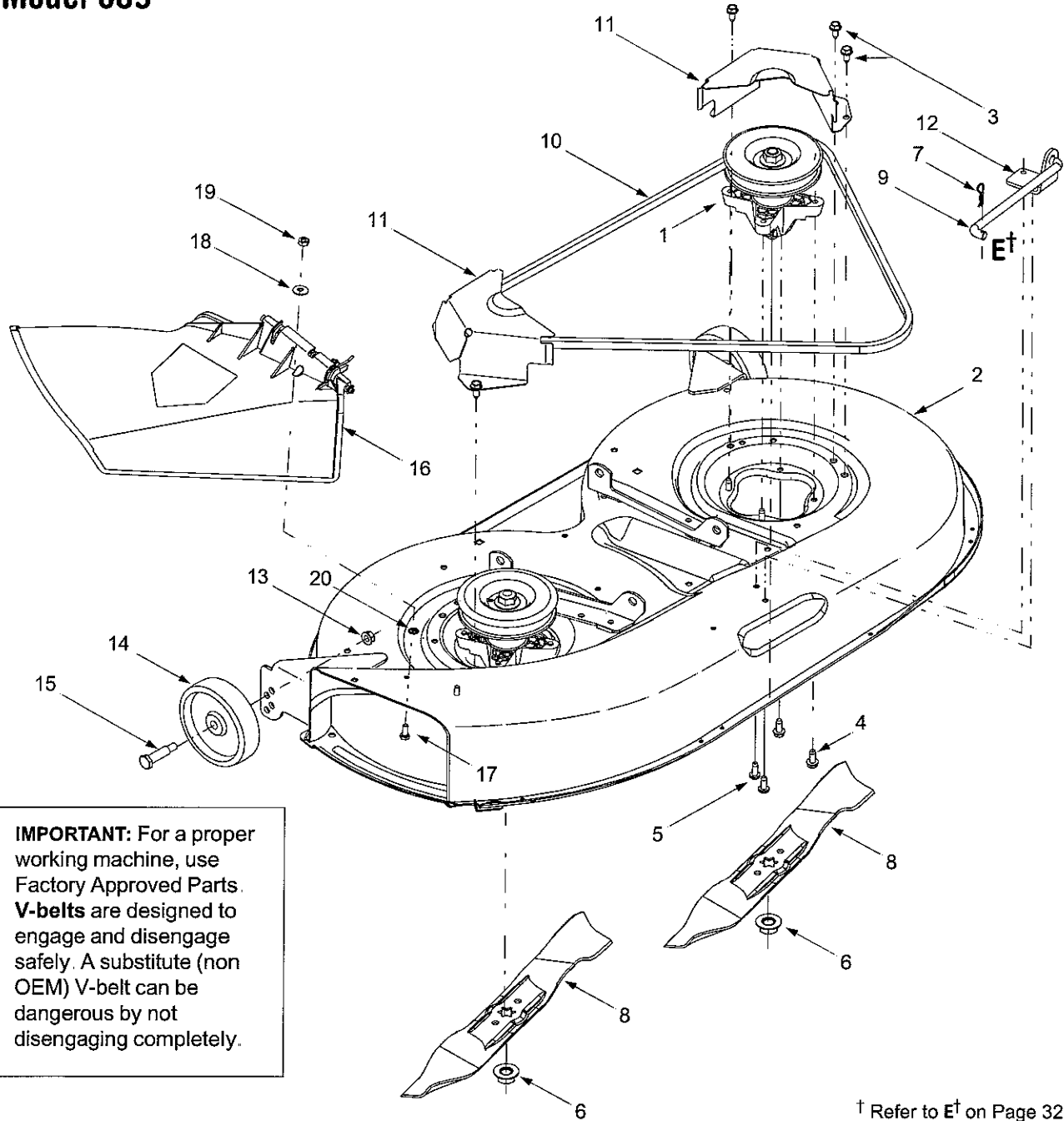

IMPORTANT: For a proper working machine, use Factory Approved Parts. **V-belts** are designed to engage and disengage safely. A substitute (non OEM) V-belt can be dangerous by not disengaging completely.

† Refer to E† on Page 32

REF. NO.	PART NO.	DESCRIPTION	REF. NO.	PART NO.	DESCRIPTION
1	618-0142A	Spindle Assembly	11	783-04149B	Belt Cover
2	683-04035A	Deck Shell	12	783-04211	Anti-sway Stabilizer Bracket
3	710-0726	Self-tapping Screw, 5/16-12 x .75	13	712-0431	Flange Lock Nut, 3/8-16
4	710-1260A	Screw, 5/16-18 x .75	14	734-0973	Deck Wheel, 5 x 1.38
5	710-1611B	Self-tapping Screw, 5/16-18 x .75	15	738-0373	Shoulder Screw, .498 x 1.53
6	712-0417A	Hex Flange Nut, 5/8-18	16	731-1032B	Discharge Chute Assembly
7	714-04023	Internal Cotter Pin, .080 x 1.56	17	710-0751	Hex Cap Screw: 1/4-20 x .620
8	742-0611B	Blade, 21.23"	18	736-0270	Bell Washer, .265 x .75 x .062
9	747-04018	Deck Hanger Link/Anti-sway Rod	19	712-3006	Hex Nut, 1/4-20
10	754-0371A	Deck Belt	20	726-0233	Push Nut, 1/4

Model 689

