

93900 to 93999

Illustrated Parts List

Model Series

93900 to 93999

Non-Compliance

TYPE NUMBERS
0100, 0101,
0115 through 0160
0200, 0201, 0215,
0216, 0217, 0223,
0224, 0225, 0226,
0229, 0230, 0231,
0232, 4001, 4002,
4004, 4005, 5500,
5501, 5505.

Compliance

TYPE NUMBERS
3100,
3111 through 3137
3177, 3178, 3201,
7001.

TO FIND

THE CORRECT NUMBER OF THE PART YOU NEED: FOLLOW THE INSTRUCTIONS BELOW

- A. Refer to Engine Model, Type and Code Number that is stamped on the blower housing of engine. Engine type numbers such as 0123 01 are listed only as 0123 in most instances. The two digits (01 or 02, etc.) to the right of the space may be required for more accurate parts identification in some instances. Select the Illustrated Parts List covering the correct Model Series and Type Number.
- B. Refer to the Illustrations and compare the original part with Illustration. The number next to the illustration is the Reference Number. Assemblies include all parts shown in frames. All parts shown in assembly frames having individual reference numbers can be purchased separately.
- C. After the Reference Number has been identified, refer to the Numerical text, where Reference and Primary Part Number are listed. **THE PRIMARY PART IS USED ON ALL TYPE NUMBERS EXCEPT THOSE TYPE NUMBERS UNDER "NOTE."**
- D. If a "Note" appears below the Primary Part Number, it means that this part differs from the Primary Part for certain types. If your Type number is listed under "Note," order the part referred to at the "Note."
- E. If your Engine Type Number does not appear after any part number listed under "Note," use the Primary Part Number.
- F. For Engine Type Numbers not covered by this book, check other Parts Lists having the same engine model or contact your source of supply.



93900 to 93999

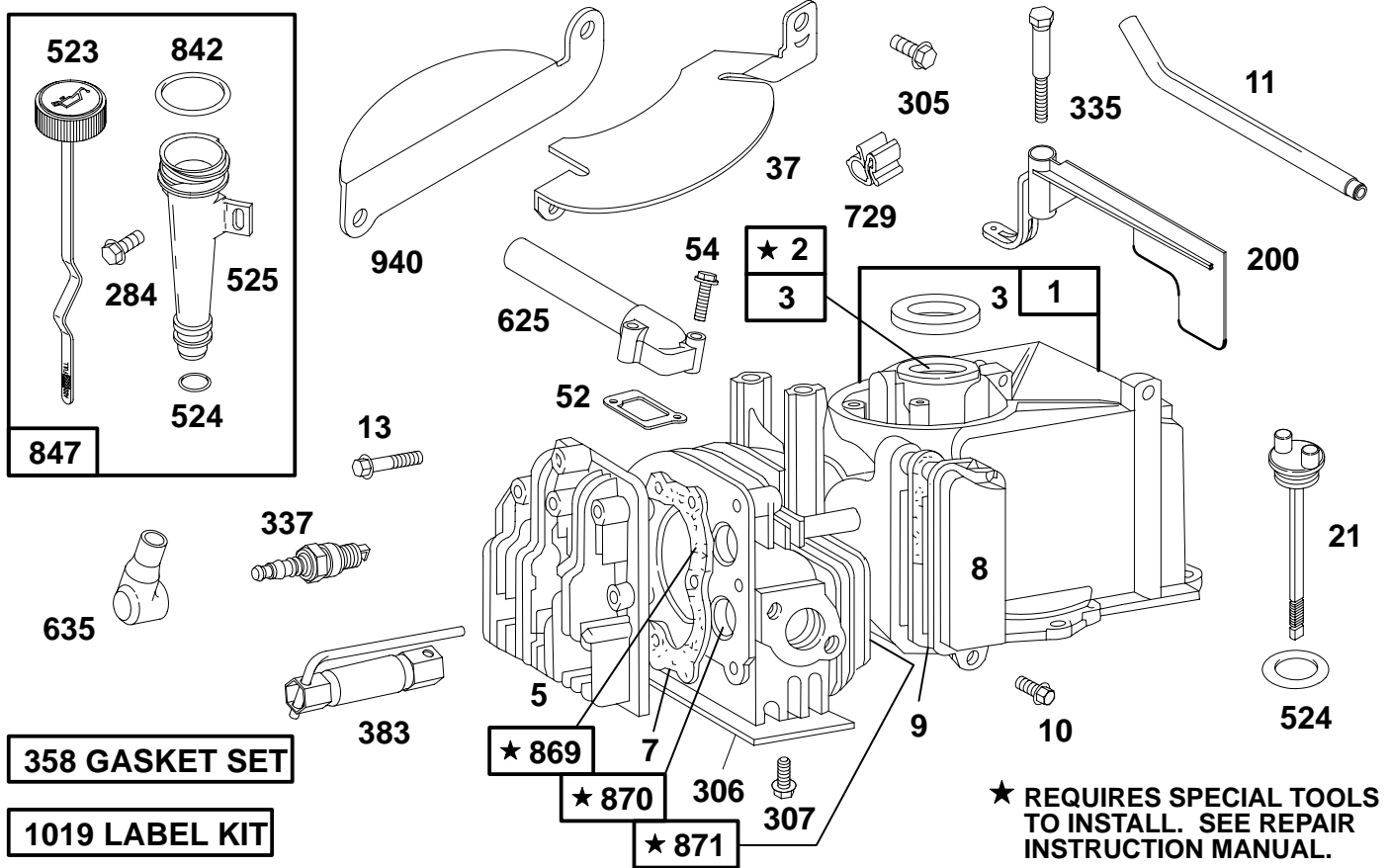

REF. NO.	PART NO.	DESCRIPTION	REF. NO.	PART NO.	DESCRIPTION	REF. NO.	PART NO.	DESCRIPTION
1	399164	Cylinder Assembly	37	223150	Guard-Flywheel	383	89838	Wrench-Spark Plug
2	293708	Bushing-Cyl.	52	*270345	Gasket-Intake Elbow	523	396372	Cap With Dipstick-Oil Fill
3	*299819	Seal-Oil	54	93485	Screw-Int. Elbow Mtg.	524	*271485	Seal-Fill Tube
5	211479	Head-Cylinder	200	68388	Blade-Governor	525	280578	Tube-Oil Fill
	Note: 213942	Head-Cylinder Used on Engines with Muffler Guard.	284	94073	Screw-Clamp Mtg.	625	298775	Tube-Fuel Intake
7	*272170	Gasket-Cylinder Head	305	94153	Screw-Blow. Hsg. Mtg.	635	66538	Elbow-Spark Plug
8	298383	Breather-Vlv. Chamber	306	221805	Cylinder-Shield	729	280470	Clip-Wire
9	*270239	Gasket-Valve Cover	307	93758	Screw-Cylinder Shield Mtg.	842	270920	Seal-Oil Fill Cap
10	93394	Screw-Sem	335	93435	Screw-Armature and Gov. Blade Mounting	847	399030	Tube Assy.-Oil Fill
11	231272	Tube-Breather	337	298809	Plug-Spark (1-1/2" High, 38 mm)	869	211172	Seat-Intake Valve (Standard)
13	93111	Screw-Cylinder Head (1-15/16" Long)		Note: 293918	Plug-Spark (Resistor Type)	870	211291	Seat-Exhaust Valve (Standard)
	Note: 93772	Stud-Cylinder Head (1)		492167	Plug-Spark (1-7/8" High, 48 mm)	871	231348	Guide-Exhaust Valve
	22963	Washer-Cylinder Head Used on Type Nos. 0230, 7001.		802592	Plug-Spark (Resistor Type) (1-7/8" High, 48 mm)		Note: 63709	Guide-Int. Valve
21	280485	Plug-Oil Fill	358	298989	Gasket Set	940	222403	Guard-Flywheel
						1019	491082	Label Kit

* Included in Gasket Set-Part No. 298989.

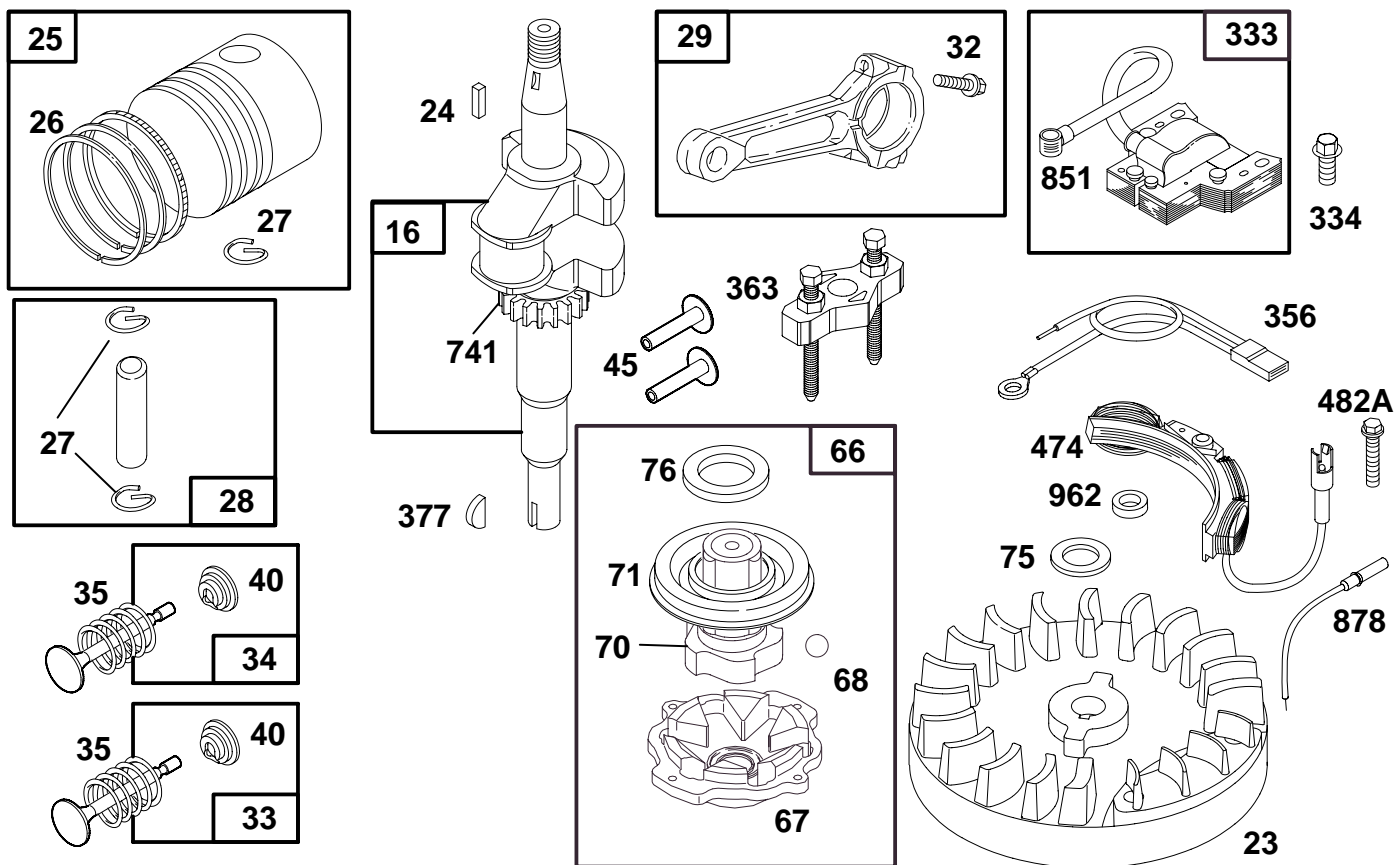

REF. NO.	PART NO.	DESCRIPTION	REF. NO.	PART NO.	DESCRIPTION	REF. NO.	PART NO.	DESCRIPTION
16		Crankshaft See Last Pages.	27	26026	Lock-Piston Pin	68	63770	Ball-Clutch
23		Flywheel-Magneto See Last Pages.	28	298909	Pin Assembly-Piston (Standard)	70	298799	Ratchet-Rewind Starter
24	222698	Key-Flywheel	298908	Pin Assembly-Piston (.005" O.S.)	71	394506	Washer-Clutch Ret.	
25	298904	Piston Assy. (Standard)	29	294201	Rod Assy.-Connecting Note: For Connecting Rod with .020" Undersize Crankpin Bore-Order No. 296079.	75	223047	Washer-Spring
	298905	Piston Assy. (.010" O.S.)	32	94404	Screw-Connecting Rod	76	68238	Washer-Ratchet Sealing
	298906	Piston Assy. (.020" O.S.)	33	296676	Valve-Exhaust	333	398593	Armature-Magneto
	298907	Piston Assy. (.030" O.S.)	34	296677	Valve-Intake	334	93381	Screw-Arma. Mtg.
26	298982	Ring Set-Piston (Standard)	35	260552	Spring-Intake Valve	356	398808	Wire-Ground
	298983	Ring Set-Piston (.010" O.S.)	40	93312	Retainer-Valve Spring	363	19069	Puller-Flywheel
	298984	Ring Set-Piston (.020" O.S.)	45	230173	Tappet-Valve	377	93065	Key-Woodruff
	298985	Ring Set-Piston (.030" O.S.)	66	399671	Clutch Assembly-Rewind Starter	474	397880	Alternator Assy.
			67	394897	Housing-Starter Clutch	482A	94016	Screw-Hex. Head
						741	261533	Gear-Timing
						851	221798	Terminal-Ignition Cable
						878	393422	Wire Assy.-Alternator
						962	231277	Bushing-Brake Lever

93900 to 93999

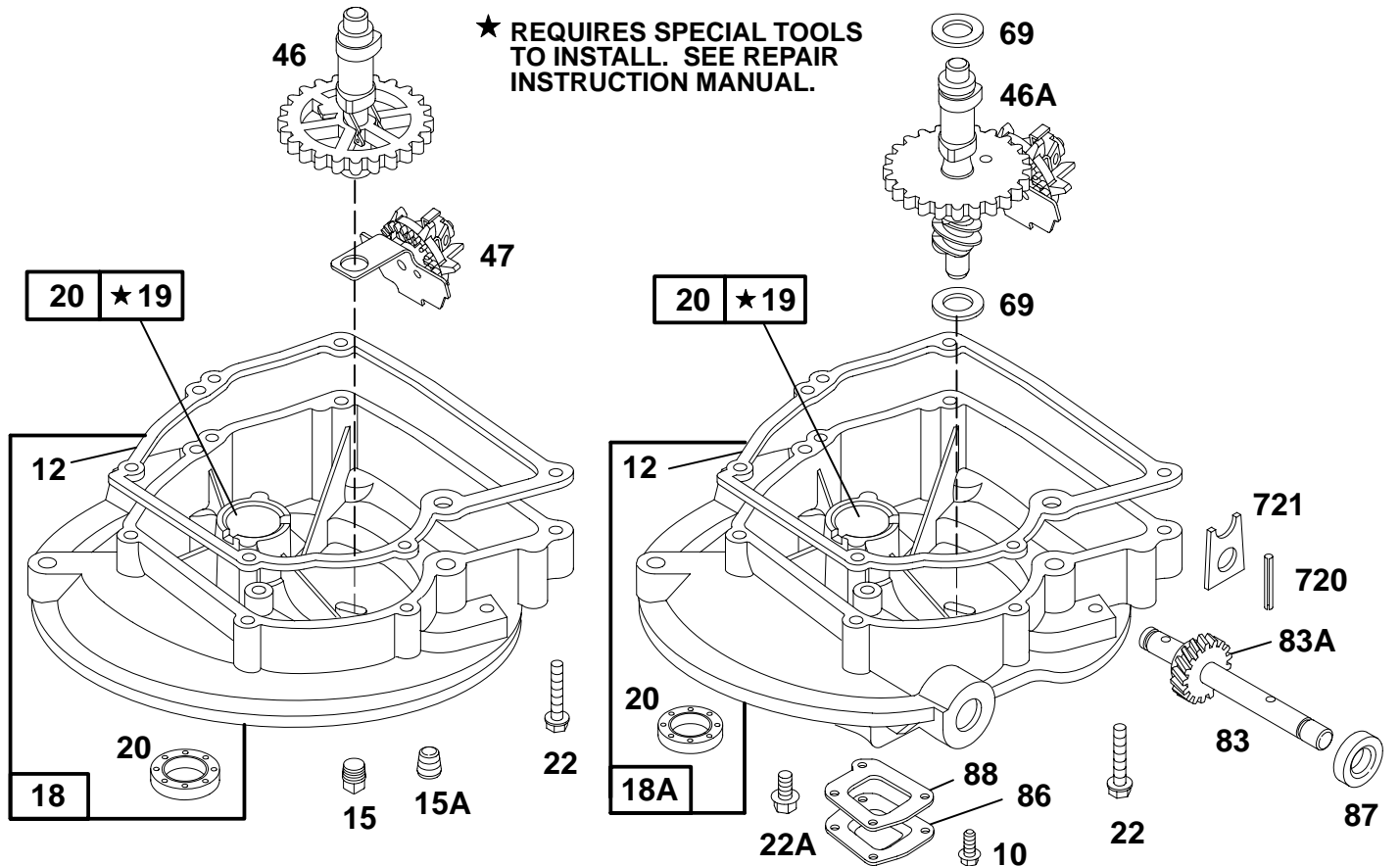

REF. NO.	PART NO.	DESCRIPTION	REF. NO.	PART NO.	DESCRIPTION	REF. NO.	PART NO.	DESCRIPTION
10	93394	Screw—Sem	22A	93415	Screw—Mtg. Sem	83	230831	Shaft—Drive
12	★270833	Gasket—Crankcase (.015" Thick, Standard)			One Used in Auxiliary Drive Gear Sump on Model 93980 to 93989 Series Engines.			Note: 230948 Shaft—Drive Used on Type Nos. 3115, 3123, 3124, 3126, 3128, 3132.
	★270895	Gasket—Crankcase (.005" Thick)						231213 Shaft—Drive Used on Type No. 3123.
	★270896	Gasket—Crankcase (.009" Thick)	46	491675	Gear—Cam	83A	231278	Gear—Drive
15	91084	Plug—Oil Drain (Square Head)			Note: 493747 Gear—Cam Used on Type Nos. 0200, 0201, 0215, 0216, 0217, 0223, 0224, 0225, 0226, 0229, 0230, 0232, 3201.			Note: 231279 Gear—Drive Used on Type Nos. 0231, 3115, 3123, 3124, 3126, 3128, 3132.
15A	93418	Plug—Oil Drain Hex. Socket	46A	396197	Cam—Cam	86	221780	Cover—Sump
18	395384	Sump—Engine			See Last Pages.	87	391484	Seal—Oil
18A	395390	Sump—Engine Used on Model 93980 to 93989 Series Engines.	47	491688	Oil Slinger Gear and Bracket	88	★270328	Gasket—Sump Cover
19	293709	Bushing—Engine Sump	69	68938	Washer—Thrust	720	93474	Pin—Gear to Shaft
20	★391483	Seal—Oil				721	221779	Stop—Drive Shaft
22	93032	Screw—Mtg. Sem						

★ Included in Gasket Set—Part No. 298989.

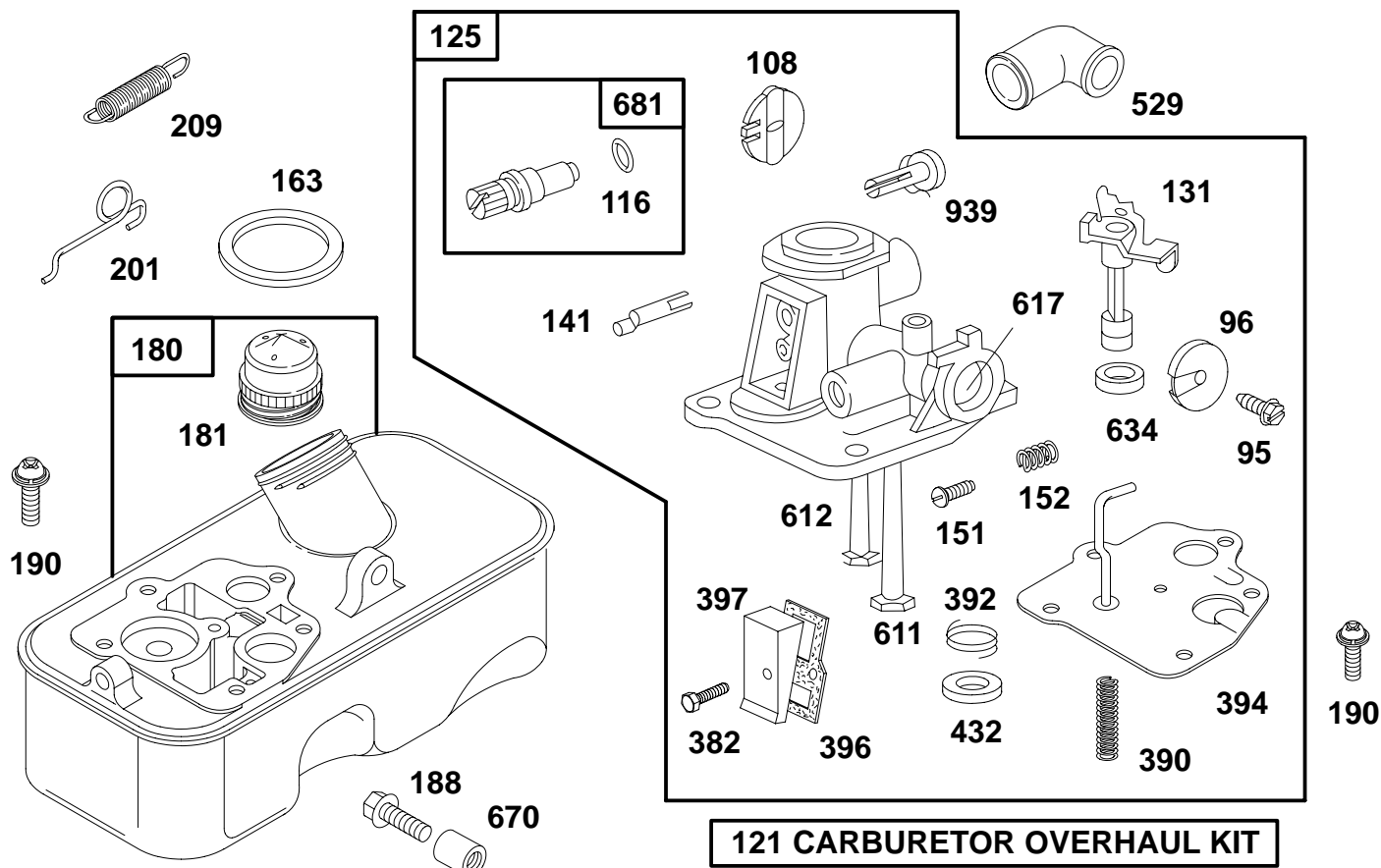

121 CARBURETOR OVERHAUL KIT

REF. NO.	PART NO.	DESCRIPTION	REF. NO.	PART NO.	DESCRIPTION	REF. NO.	PART NO.	DESCRIPTION	
95	93499	Screw-Thr. Vlv. Mtg.	201	261027	Link-Governor	397	211678	Cover-Choke Link	
96	211237	Valve-Throttle		Note: 260878	Link-Gov. Used on Type Nos. 0120, 0123, 0129, 0135, 0138, 0139, 0140, 0143, 0145, 0152, 0155, 0159, 0217, 0223, 0224, 0226, 0229, 0230, 3137, 4004, 4005.	432	221377	Cap-Spring	
108	280370	Valve-Choke				529	280368	Grommet-Breather	
116	●280203	O-Ring				611	297219	Pipe-Fuel (Long)	
121	494623	Carburetor Overhaul Kit				612	296811	Pipe-Fuel (Short)	
125	395957	Carburetor Assembly				617	●270344	Seal-Fuel Intake Tube	
131	299977	Shaft and Lever-Thr.				634	270167	Washer-Throttle Shaft (Felt)	
141	68908	Shaft-Choke				670	94047	Spacer-Fuel Tank Used on Engines Without Band Brake.	
151	93524	Screw-Rd. Hd.					Note: 94038	Spacer-Fuel Tank Used on Engines With Band Brake.	
152	260746	Spring-Throttle Adj.	209		Spring-Governor				
163	★●271139	Gasket-Air Cleaner Mounting			See Last Pages.				
180	396781	Tank Assembly-Fuel	382	93545	Screw-Choke Link Cover				
181	298425	Cap-Fuel Tank	390	261249	Spring-Diaphragm				
188	94102	Screw-Fuel Tank and Starter Mounting	392	260455	Spring-Fuel Pump Diaphragm				
190	93440	Screw-Fuel Tank Mtg.	394	●391681	Diaphragm-Carburetor		681	●395508	Needle Valve Kit (Nylon Body)
			396	●270571	Gasket-Choke Link Cover		939	395665	Shaft Assembly-Choke

● Included in Carburetor Overhaul Kit-Part No. 494623.

93900 to 93999

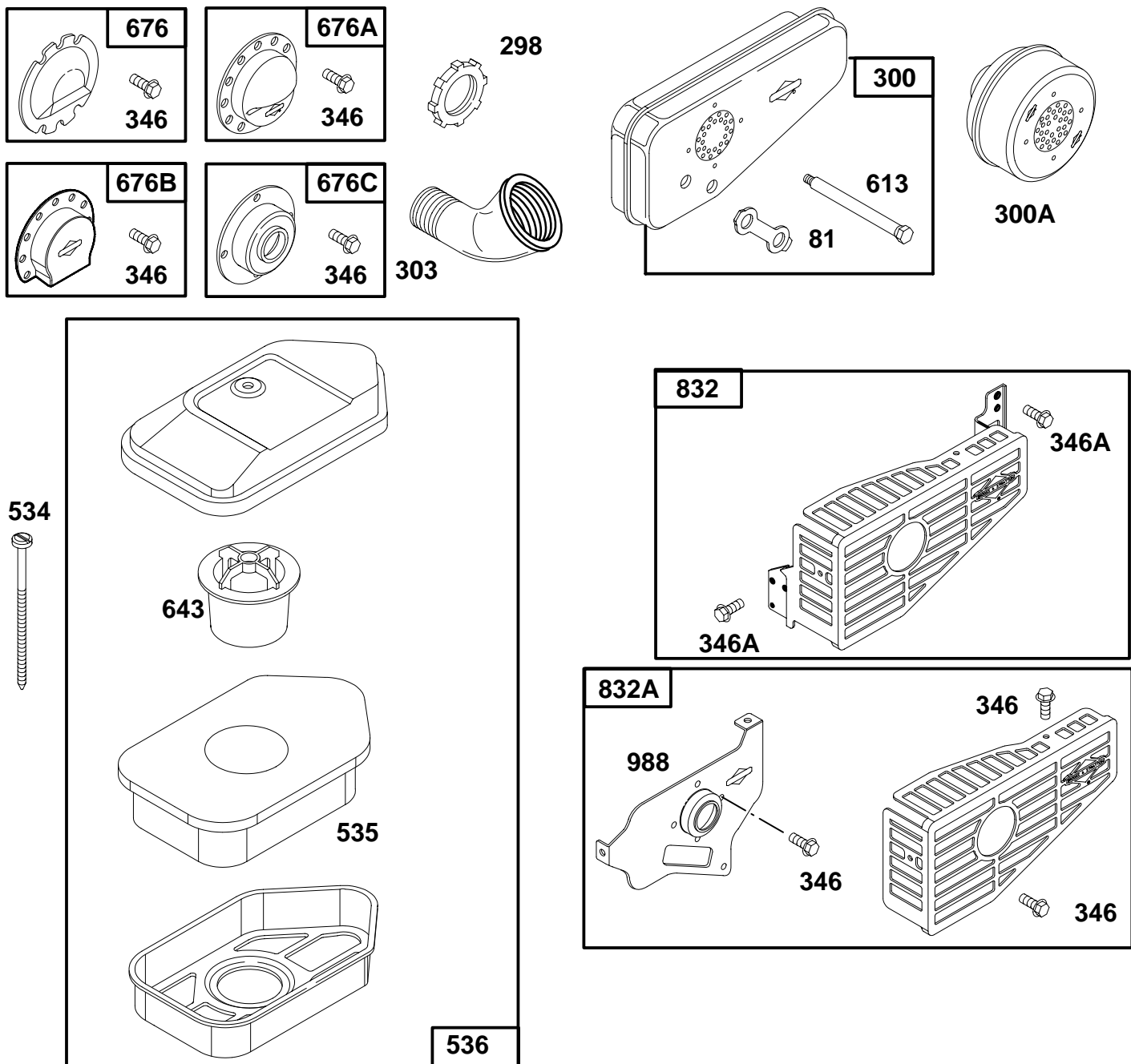

REF. NO.	PART NO.	DESCRIPTION	REF. NO.	PART NO.	DESCRIPTION	REF. NO.	PART NO.	DESCRIPTION
81	223256	Lock-Muffler Screw	534	93865	Screw-Air Cleaner	676B	393760	Deflector-Muffler
298	220859	Locknut-Muffler	535	272235	Element-Air Cleaner	676C	397931	Deflector-Muffler
300	394644	Muffler-Exhaust	536	493492	Cleaner-Air	832	494896	Guard-Muffler
300A	394569	Muffler-Ex. (Lo-Tone)	613	93935	Screw-Muffler Mtg.	832A	493967	Guard-Muffler
303	92989	Elbow-Exhaust	643	280972	Cup-Air Cleaner	988	223600	Bracket-Muffler
346	93705	Screw-Hex. Head	676	393756	Deflector-Muffler			
346A	94602	Screw-Hex. Head	676A	396548	Deflector-Muffler			

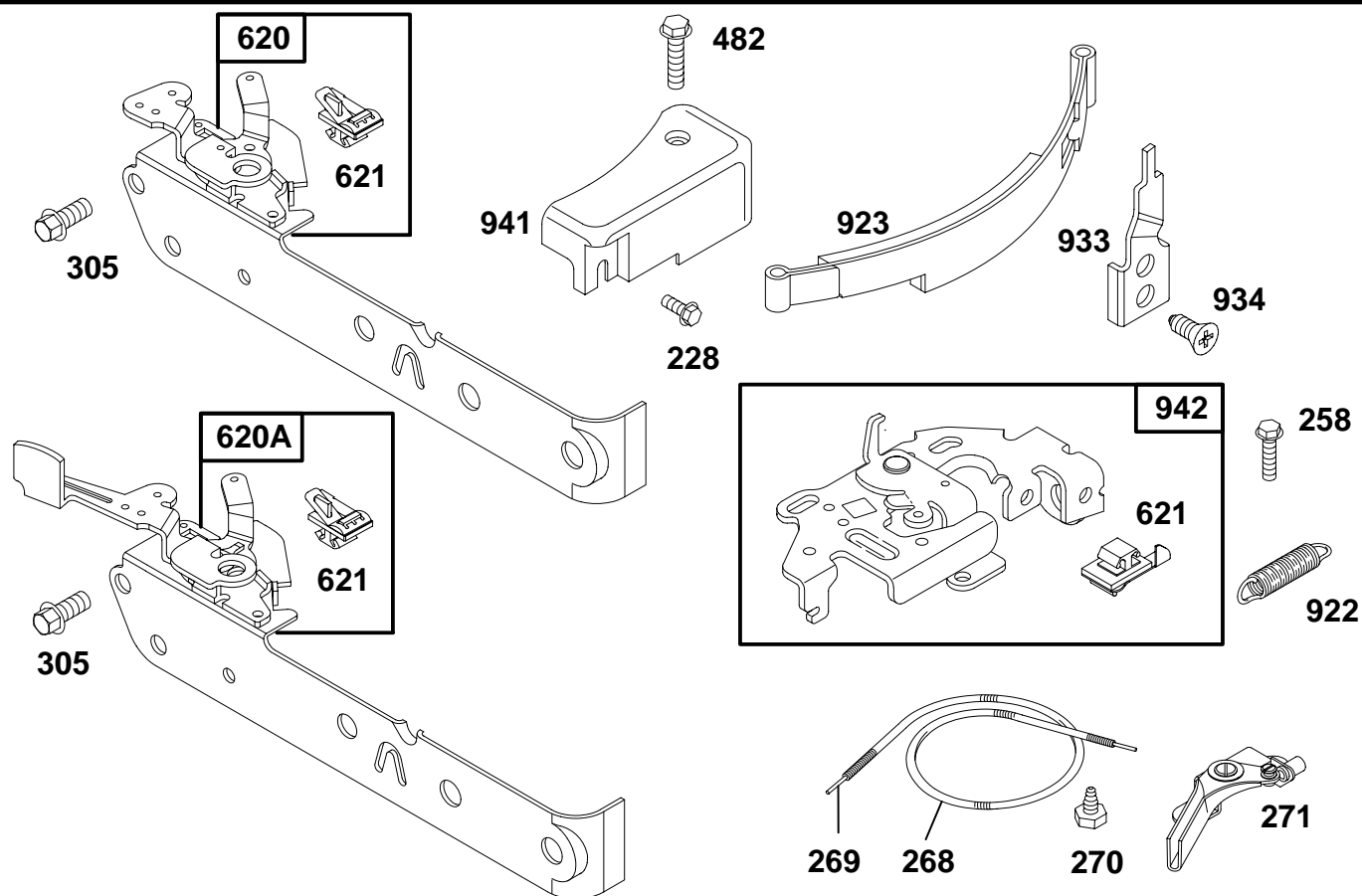

REF. NO.	PART NO.	DESCRIPTION	REF. NO.	PART NO.	DESCRIPTION	REF. NO.	PART NO.	DESCRIPTION
228	93758	Screw—Hex. Head			Long)	482	93621	Screw—Sem
258	94018	Screw—Sem (Bracket to Cylinder)			Note: If Longer Wire is Needed, Specify Length in Inches; if Shorter Wire is Needed, Order No. 26099 and Cut to Required Length.	620	299974	Plate—Carburetor Control
268	66986	Casing—Control Wire (48" Long) Note: If Longer Casing is Needed, Specify Length in Inches; if a Shorter Casing is Needed Order No. 66986 and Cut to Required Length.	270	63426	Locknut—Control Wire Casing	620A	299975	Plate—Carburetor Control
269	26099	Wire Control (54"	271	290568	Lever Assembly Control	621	396847	Switch—Stop
			305	94153	Screw—Blo. Hsg. Mtg.	922	261647	Spring—Band Brake
						923	394867	Brake Assembly—Band
						933	223448	Pivot—Band Brake
						934	94037	Screw—Band Brake Pivot
						941	280395	Cover—Linkage
						942	493248	Bracket Assy.—Lever

93900 to 93999

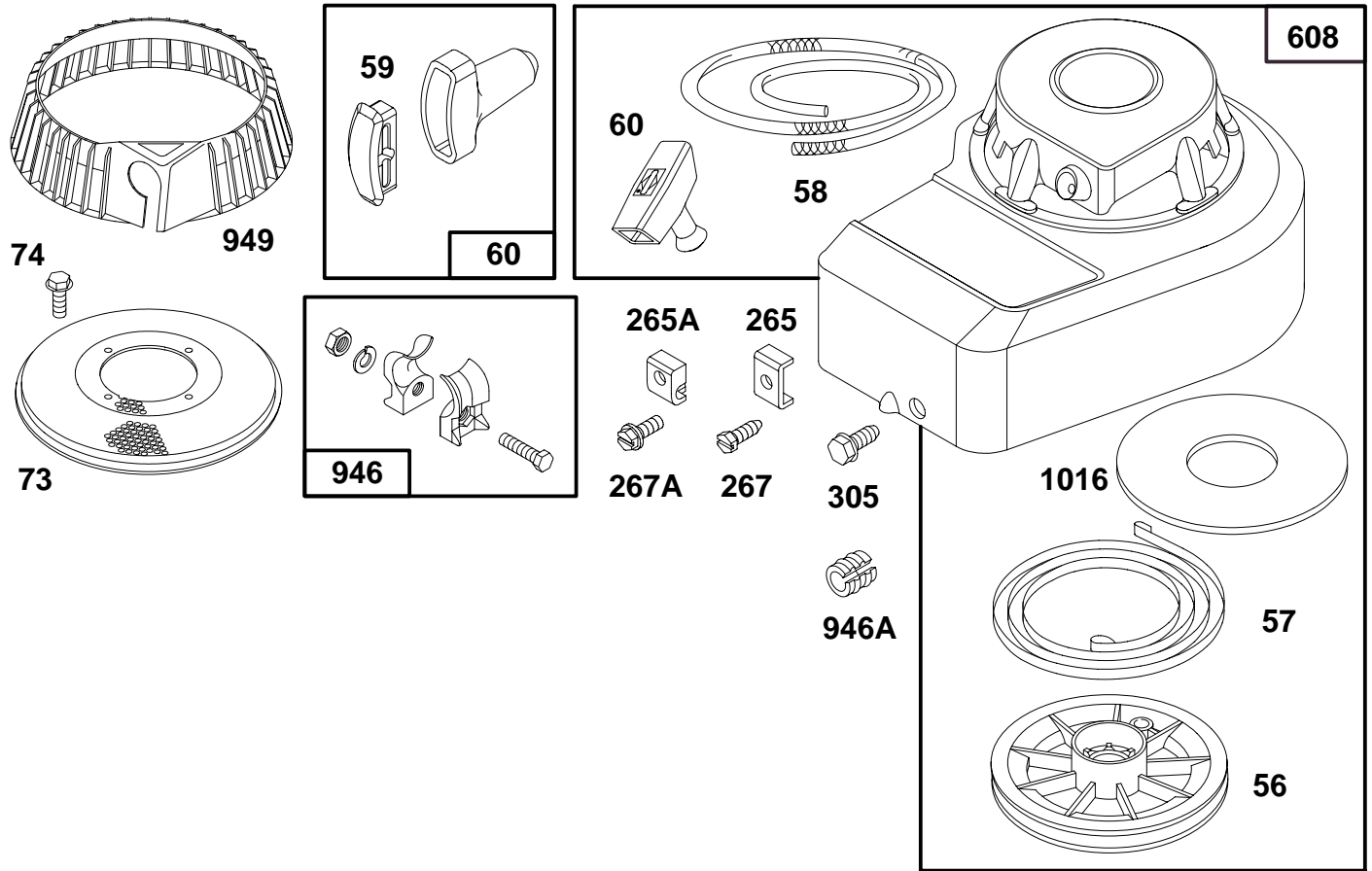

REF. NO.	PART NO.	DESCRIPTION	REF. NO.	PART NO.	DESCRIPTION	REF. NO.	PART NO.	DESCRIPTION
56	280439	Pulley—Rewind Starter	73	221661	Screen—Rewind Starter			90832 Lockwasher
57	490179	Spring—Rewind Starter	74	93758	Screw—Sem			92278 Nut—Hex.
58	280406	Rope—Rewind Starter (81" Long) (For Intermediate Lengths, Cut to Required Size). Note: If Longer Rope is Needed, Order No. 280399 and Cut to Required Length.	265	22372	Clamp—Casing	946A	223294	Rope—Stop
59	396892	Insert—Starter Rope	265A	213146	Clamp—Casing	949	281192	Guard—Rewind Starter (Used After Code Date 91080400).
60	393152	Grip—Starter Rope	267	93469	Screw—Clamp Mtg.			Note: 280684 Guard—Rewind Starter (Used Before Code Date 91080500).
			267A	94204	Screw—Clamp Mtg.	1016	490817	Spacer—Rewind Starter
			305	94153	Screw—Blo. Hsg. Mtg.			
			608	608	Starter Assy.—Rewind See Last Pages.			
			946	396526	Rope Guide Kit Includes:			
					92636 Screw—Hex.			

REF. NO.	PART NO.	DESCRIPTION	REF. NO.	PART NO.	DESCRIPTION	REF. NO.	PART NO.	DESCRIPTION
16	492748	Crankshaft Note: To Replace Crankshaft Gear Pin, Order Part No. 230978 . 397224 Crankshaft Used on Type Nos. 3112, 3119, 3122, 3123, 3126, 3177, 3178, 492086 Crankshaft Used on Type Nos. 0118, 0119, 0121, 0122, 0123, 0124, 0126, 0135, 0138, 0143, 0145, 0146, 0147, 0148, 0149, 0154, 0155, 0157, 0159, 0201, 0215, 0216, 0217, 0223, 0226, 0229, 3111, 3116, 3117, 3118, 3120, 3124, 3132, 3201, 4002, 4005, 5501, 5505, 7001. 493618 Crankshaft Used on Type Nos. 0230, 3133. 493846 Crankshaft Used on Type Nos. 3121, 3125. 494564 Crankshaft (Used After Code Date 91063000). 494034 Crankshaft (Used Before Code Date 91070100). Used on Type Nos. 0129, 0140, 0150, 3127, 3131.	46A	396197	Gear–Cam (Clockwise) Note: 395317 Gear–Cam (Counterclockwise) Used on Type Nos. 0231, 3115, 3123, 3124, 3126, 3128, 3132. 209 260875 Spring–Governor Note: 260877 Spring–Gov. Used on Type Nos. 0100, 0115, 0116, 0117, 0128, 0130, 0131, 0136, 0138, 0144, 0145, 0147, 0160, 3100, 3111, 3129, 3133. 261034 Spring–Gov. Used on Type Nos. 0148, 0154, 0155, 0200, 0201, 0215, 0216, 0217, 0223, 0224, 0229, 0231, 3100, 3137, 3201, 5500, 5501, 5505. 261060 Spring–Gov. Used on Type Nos. 0118, 0119, 0120, 0122, 0126, 0127, 0129, 0135, 0142, 0143, 0150, 3116, 3119, 3178. 261105 Spring–Gov. Used on Type No. 0116. 261106 Spring–Gov. Used on Type Nos. 0124, 0133, 0146, 0230, 3112, 3113, 3114, 3115, 3117, 3118, 3120, 3121, 3122, 3123, 3124, 3125, 3127, 3128, 3130, 3131, 3132, 3134, 3136, 3177, 4001, 4002, 4004, 4005, 7001. 261320 Spring–Gov. Used on Type Nos. 0142, 0149, 3116.	608		261419 Spring–Gov. Used on Type Nos. 0225, 3135. 261948 Spring–Gov. Used on Type Nos. 0101, 0121, 0125, 0134, 0137, 0139, 0140, 0152, 0157, 0158, 3101, 3126. 608 Starter Assy.–Rewind See Chart on Illustrated Page. Note: 493797 Starter Assy.–Rewind (1:30 o'clock, For Non-Band Brake) 493488 Starter Assy.–Rewind (3 o'clock, For Non-Band Brake) See Below For Specials. 494738 Starter Assy.–Rewind (3 o'clock, For Band Brake) 494571 Starter Assy.–Rewind (3 o'clock) Used on Type Nos. 0200, 0201, 0230, 0231, 0232. 494917 Starter Assy.–Rewind (3 o'clock) Used on Type No. 0217. 494143 Starter Assy.–Rewind (4 o'clock, For Non-Band Brake) 493479 Starter Assy.–Rewind (5 o'clock, For Band Brake) 494509 Starter Assy.–Rewind (5 o'clock, For Non-Band Brake) See Below For Specials. 493748 Starter Assy.–Rewind (5 o'clock) Used on Type Nos. 0135, 0143, 0229. 493596 Starter Assy.–Rewind (6 o'clock, For Band Brake)
23	395653	Flywheel–Magneto Note: 394066 Flywheel–Magneto Used on Type Nos. 0120, 0123, 0129, 0135, 0138, 0139, 0140, 0143, 0145, 0150, 0152, 0155, 0159, 0217, 0223, 0224, 0226, 0229, 0230, 3137, 4004, 4005.						

93900 to 93999

REF. NO.	PART NO.	DESCRIPTION	REF. NO.	PART NO.	DESCRIPTION	REF. NO.	PART NO.	DESCRIPTION
		493481 Starter Assy.– Rewind (6 o'clock, For Non-Band Brake) See Below For Specials. 493617 Starter Assy.– Rewind (6 o'clock) Used on Type Nos. 0123, 0159, 0223, 0226.			494123 Starter Assy.– Rewind (6 o'clock) Used on Type Nos. 0144, 0225. 493594 Starter Assy.– Rewind (8 o'clock, For Non-Band Brake) 493660 Starter Assy.– Rewind (8 o'clock, For Band Brake)			493493 Starter Assy.– Rewind (9 o'clock, For Band Brake) 493565 Starter Assy.– Rewind (9 o'clock, For Non-Band Brake) 493300 Starter Assy.– Rewind (12 o'clock, For Band Brake) 493469 Starter Assy.– Rewind (12 o'clock, For Non-Band Brake)