

1708579
311-0500

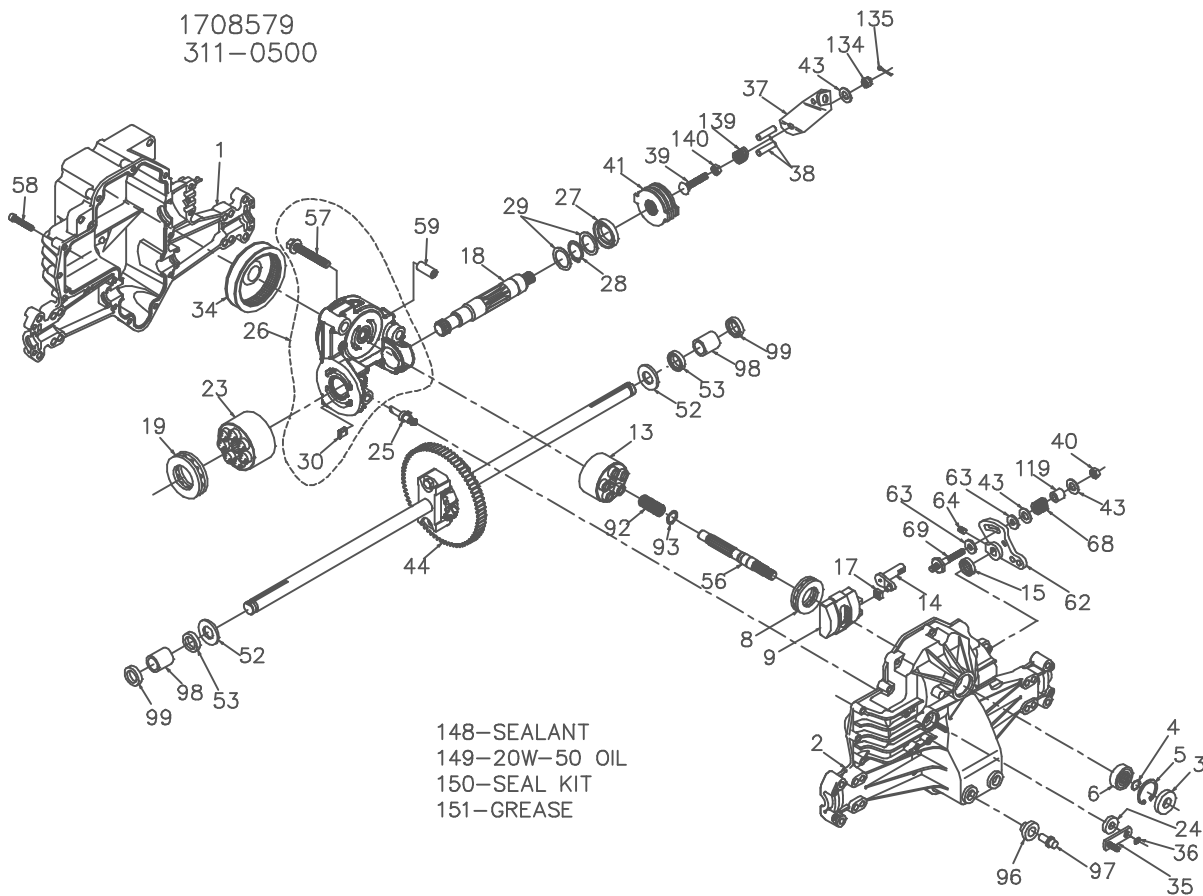

1708579
311-0500

ITEM NO	HYDRO-GEAR PART NO	QTY	DESCRIPTION	ITEM NO	HYDRO-GEAR PART NO	QTY	DESCRIPTION
1	44863RM	1	HOUSING, LOWER	39	50316	1	BOLT-5/16-24 X 1-3/4
2	70254	1	ASSEMBLY, UPPER HOUSING	40	50317	1	NUT-HEX LOCK 5/16-24 UNJC
		1	UPPER HOUSING	41	70135	1	BRAKE ROTOR/STATOR KIT
3	9008000-0128	1	TRUNNION JOURNAL BEARING			4	BRAKE STATOR
4	2003016	1	SEAL-LIP	43	44130	2	BRAKE ROTOR
5	2003052	1	RING-WIRE RETAINING	44	70126	3	WASHER-7/16 X 7/8 X .060
6	2003043	1	RING-RETAINING			1	DIFFERENTIAL ASSEMBLY
8	50551	1	BEARING-SHAFT BALL			2	AXLE SHAFT
9	2003087	1	BEARING-THRUST 30X52X13			1	72T DIFFERENTIAL GEAR
13	70331	1	SWASHPLATE-VARIABLE			2	DIFFERENTIAL HOUSING
		1	BLOCK-CYLINDER ASS'Y.			2	14T BEVEL GEAR
		1	BLOCK-CYLINDER			2	10T PLANET GEAR
		5	PISTON			2	RETAINING RING
		5	PISTON SPRING			2	DIFFERENTIAL LOCKING BOLT
		5	PISTON SPRING WASHER	52	44875	1	DIFFERENTIAL SPACER
14	2003005	1	ARM-TRUNNION	53	45076	2	WASHER-3/4 X 1.5 X .13
15	9008000-0126	1	SEAL-LIP	56	50005	2	SEAL- .75 X 1.25 X .250
17	2000015	1	GUIDE-SLOT	57	50016	1	SHAFT-INPUT
18	50449	1	SHAFT-MOTOR	58	50016	3	BOLT, 3/8-24 X 2.5
19	50552	1	BEARING-THRUST 42X68X16	58	44876	20	BOLT- 1/4-20 X 1.38
23	70082	1	BLOCK-CYLINDER ASS'Y.	59	50002	2	PIN- .5 OD X .43 ID X .750
		1	BLOCK-CYLINDER	62	50254	1	ARM-CONTROL
		7	PISTON	63	50281	2	PUCK-DAMPENER
		7	PISTON SPRING	64	50018	1	SET SCREW
		7	PISTON SPRING WASHER	68	50277	1	SPRING
24	45074	1	SEAL-LIP 10X25X7	69	50284	1	5/16-24 STUD
25	2003555	1	ACTUATOR-BYPASS	92	2003014	1	SPRING, BLOCK
26	70250	1	KIT, CENTER SECTION	93	2003017	1	WASHER, BLOCK THRUST
		1	PLATE, BYPASS	96	50133	1	BUSHING, VENT
		2	CHECK PLUG ASSEMBLY	97	50134	1	VENT
		1	CENTER SECTION	98	50137	2	SLEEVE BEARING
		1	DU BEARING	99	50941	2	SEAL, LIP 0.75X1.00X0.158
		3	BOLT, 3/8-24 X 2.5	119	50278	1	SPACER
		1	BUSHING, 1.02 X 1.1 X .67	134	44142	1	SLOTTED NUT, 5/16-24
27	45075	1	SEAL-LIP 26X42X8	135	44101	1	COTTER PIN
28	50007	1	RING-RETAINING	139	50431	1	COMPRESSION SPRING
29	44872	2	WASHER-26X35X1	140	50269	1	NUT, HEX 5/16-24
30	70680	1	KIT, BYPASS PLATE	148	50928	1	SEALANT
34	44964	1	OIL FILTER ELEMENT	149		77oz	20W-50 OIL
35	50126	1	ARM-BYPASS	150	70312	1	SEAL KIT
36	44870	1	RING-RETAINING	151	50416	1	GREASE
37	23710	1	ARM-ACTUATING				
38	44891	2	PIN-ACTUATING				