

130332
327-2400L

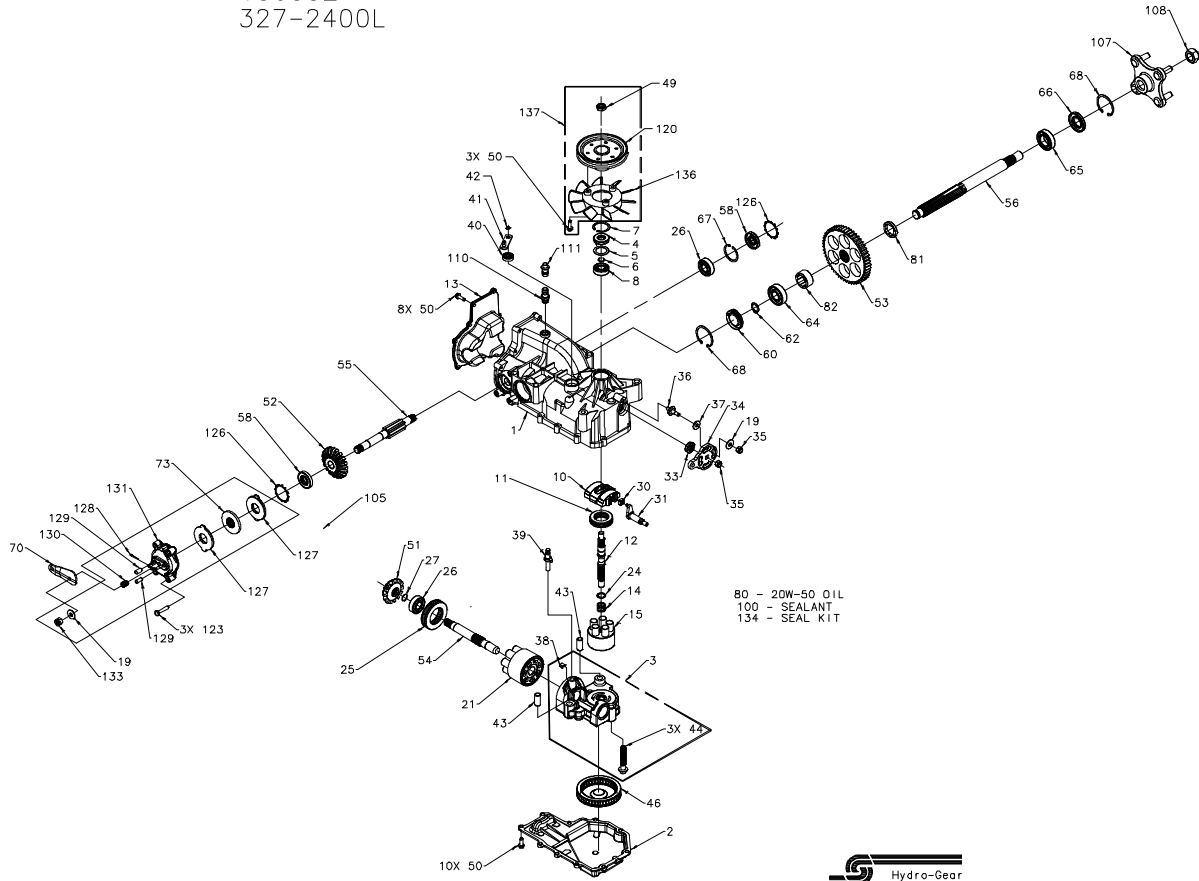

130332
327-2400L

ITEM #	PART #	QTY	DESCRIPTION	ITEM #	PART #	QTY	DESCRIPTION
1	70556	1	KIT, HOUSING-MAIN	64	50743	1	BEARING-BALL 20X47X14(6204)
		1	HOUSING, MAIN	65	50740	1	BEARING-BALL 25X47X12(6005)
		2	CRADLE BEARING	66	50751	1	SEAL
2	5089ORM	1	LIP SEAL	67	50329	1	RETAINING RING
3	70676	1	TRUNNION BUSHING	68	50760	2	RETAINING RING-AXLE
		1	LOWER HOUSING	70	51349	1	ARM, BRAKE
		1	KIT, CENTER SECTION	80	44855	1	ROTOR, BRAKE
		1	CENTER SECTION	80oz	20W-50 OIL	79oz	
		1	BUSHING .67 X 1.03 X .75	81	50942-2	1	AXLE BUSHING
		1	PLATE, BYPASS	82	50942-1	1	AXLE BUSHING
		3	SCREW 3/8-24 X 2.5	100	50928	1	SEALANT
		1	CHECK PLUG ASSEMBLY, .027	105	70561	1	KIT, BRAKE
		1	CHECK PLUG ASSEMBLY, .044			1	WASHER
4	9008000-0128	1	LIP SEAL			1	ROTOR, BRAKE
5	2003016	1	SPACER	2		2	STATOR, BRAKE FRICTION
6	2003016	1	WIRE RETAINING RING			1	COTTER PIN 3/32 X 3/4
7	2003052	1	RETAINING RING	2		2	BRAKE ACTUATING PIN
8	2003043	1	BALL BEARING			1	COMPRESSION SPRING ANTI DRAG
10	2003087	1	VARIABLE CRASHPLATE			1	KIT, YOKE-BRAKE
11	50551	1	THRUST BEARING 30 X 52 X 13			1	SLOTTED HEX NUT 5/16-24
12	50005	1	INPUT SHAFT	107	70314	1	HUB ASSEMBLY
13	50891RM	1	COVER-BACK			4	LUG BOLT
14	2003014	1	SPRING, BLOCK	108	50863	1	NUT, HEX 3/4-16
15	70331	1	10cc CYLINDER BLOCK ASS'Y	110	70110	1	FITTING O-RING ASSEMBLY
		5	10cc PISTON SPRING			1	PLASTIC HOSE FITTING
		5	PISTON SEAT WASHER			1	O-RING
		5	10cc PISTON	111	70109	1	CAP VENT ASSEMBLY
19	44130	2	WASHER			1	CAP-POCKET VALVE
21	70082	1	21cc CYLINDER BLOCK ASS'Y			1	PLASTIC VENT
		1	21cc CYLINDER BLOCK	120	50302	1	PULLEY, 4.5
		7	21cc PISTON SPRING	123	51341	3	SCREW, 1/4-28 X 1.25 W/PATCH
		7	PISTON SEAT WASHER	126	51316	2	RING, RETAINING
24	2003017	1	WASHER, BLOCK THRUST	127	51340	1	STATOR, BRAKE FRICTION
25	50552	1	THRUST BEARING 42 X 68 X 16	128	44101	1	COTTER PIN 3/32 X 3/4
26	50315	2	BALL BEARING	129	44127	2	BRAKE ACTUATING PIN
27	2000022	1	WIRE RETAINING RING	130	50919	1	COMPRESSION SPRING BRAKE ANTI DRAG
30	2000015	1	SLOT GUIDE	131	70560	1	KIT, YOKE-BRAKE
31	50807	1	TRUNNION ARM			1	SQ HD BOLT 5/16-24 RIBBED
33	9008000-0126	1	LIP SEAL			1	YOKE, BRAKE
34	50749	1	CONTROL ARM	134	44142	1	SLOTTED HEX NUT 5/16-24
35	50317	2	NUT	134	70553	1	KIT, SEAL
36	50426	1	STUD - SHORT 5/16-24			1	SEAL, LIP 15 X 35 X 7
37	50281	1	FRICTION RUCK			1	RING, RETAINING
38	70680	1	KIT, BYPASS PLATE			1	SEAL, LIP 12 X 25 X 7
39	2003555	1	BYPASS ACTUATOR			1	SEAL, LIP 10 X 25 X 7
40	45074	1	LIP SEAL			1	RING, RETAINING
41	50270	1	BYPASS ARM			2	SEAL, LIP 17 X 40 X 7
42	44870	1	RETAINING RING			1	SEAL, LIP 1.85 X .37
43	50002	2	PIN			1	RING, RETAINING
44	50016	3	SCREW			1	RING, RETAINING .440 EXTERNAL
46	50990	1	FILTER			1	SEAL, LIP .88 X 1.85 X .276
49	51244	1	HEX LOCK NUT 1/2-20 (NYLON INSERT)			1	RING, RETAINING
50	50752	21	SCREW, 1/4-20 X .75 LONG			2	RING, RETAINING
51	50744	1	14T BEVEL GEAR			1	RING, RETAINING
52	50745	1	19T BEVEL GEAR			2	SEAL, LIP 17 X 40 X 5
53	50746	1	53T SPUR GEAR	136	51365	1	FAN, 6", 10 BLADE
54	50757	1	MOTOR SHAFT	137	70591	1	KIT, FAN-PULLEY
55	51335	1	BRAKE SHAFT			3	SCREW, 1/4-20 X .75 LONG
56	50748	1	AXLE SHAFT			1	FAN, 6", 10 BLADE
58	51161	2	SEAL, LIP 17 X 40 X 7			1	HEX LOCK NUT 1/2-20 (NYLON INSERT)
60	50995	1	SEAL PLUG - SIDE			1	PULLEY, 4.5
62	50759	1	RETAINING RING - AXLE				