

**RIDGID**®

# **BS1400 OWNER'S MANUAL**

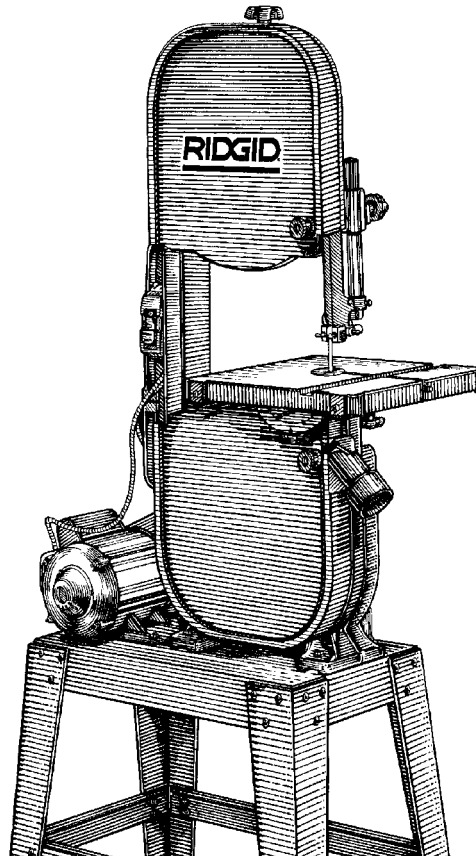

## **14 INCH BAND SAW**

- **Assembly**
- **Operation**
- **Repair Parts**

**For Your Safety:**

**Read all instructions carefully**

**QUESTIONS OR COMMENTS?**

**CALL 1-800-4-RIDGID**

Parts List For RIDGID 14-inch Band Saw  
Model No. BS14000

Figure 1

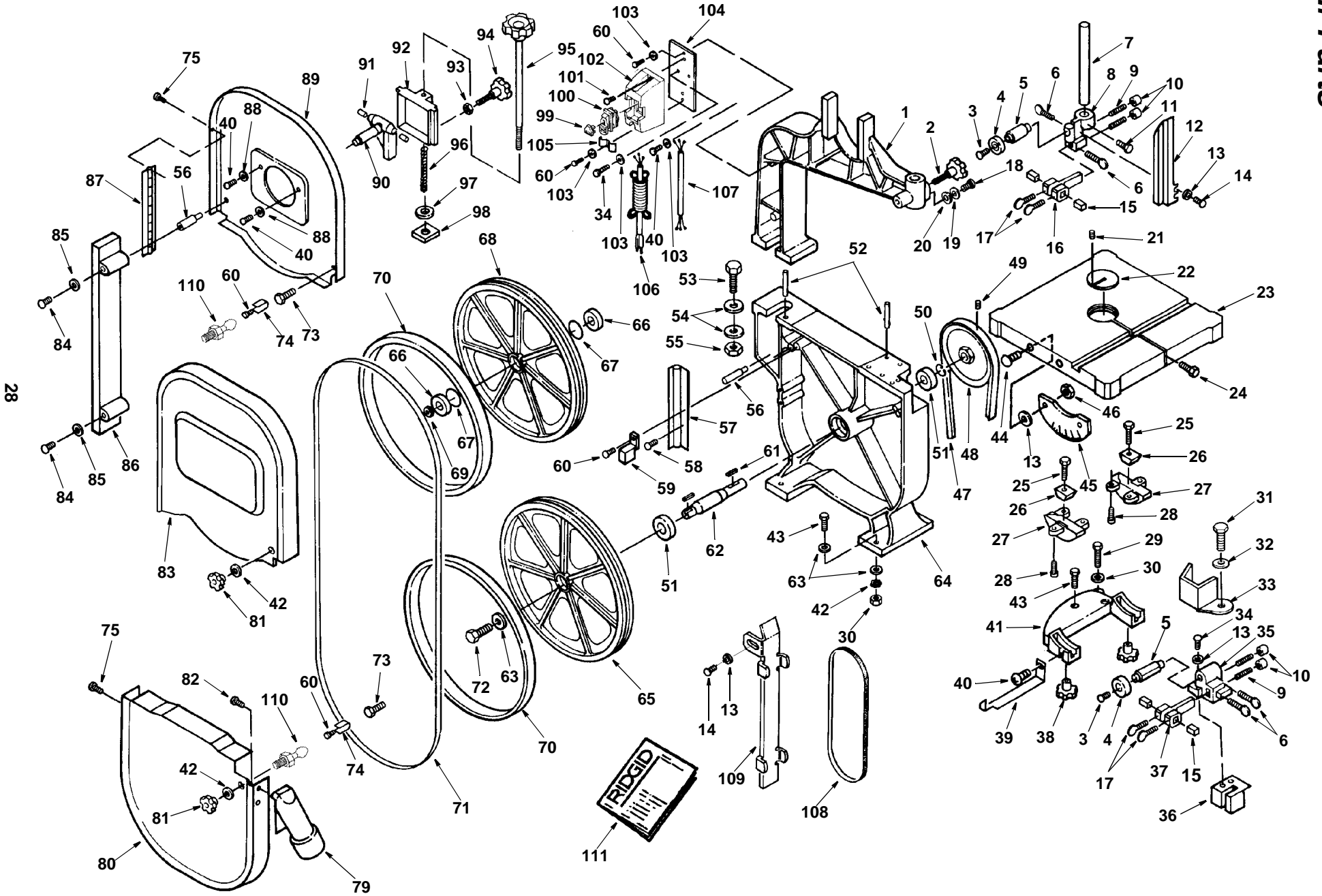

**Parts List For RIDGID 14 Inch Band Saw  
Model No. BS14000 Figure 1 - Drive Assembly Parts**

Always Order By Part Number - Not By Key Number

Key No.	Part No.	Description
1	823545-1	Frame Upper Arm
2	826533	Knob
3	823746	Screw Pan Hd. Lock M6 x 1-12
4	820722-10	Bearing Ball
5	823574	Sleeve Upper Spacing
6	823744-3	Screw Thumb M6-16
7	823575-2	Post Guide
8	823601	Bracket Support Post
9	823954	Screw Soc Set M8 x 1.25-40
10	823573	Nut Micro-Adjust
11	820249-4	Screw hex Hd. M6 x 1.0-16
12	823596	Guard Blade Upper
13	*	Washer M6
14	813307-3	Screw Hex Hd. M6 x 1.0-10
15	823572	Block Guide
16	823745	Bracket Support Upper
17	823744-2	Screw Thumb M6-12
18	*	Screw Soc. Cup M10 x 1.5-10
19	823743	Spring
20	823742	Ball Steel
21	813249-76	Pin Spring
22	823580	Insert Table
23	823559-1	Table
24	823579	Pin table
25	823769	Screw Hex Hd. M10 x 1.5-55
26	823565	Clamp Trunnion Shoe
27	823586	Trunnion
28	823768	Screw Hex Washer hd. M6 x 1-12
29	*	Screw Hex Hd. M8 x 1.25-80
30	*	Nut Hex M8
31	816755-10	Screw Pan Cross M5 x 0.8-9
32	*	Lockwasher M5.5
33	823588	Guard Blade Lower
34	*	Screw Hex Hd. M6 x 1.0-20
35	826538	Bracket Lower Support Post
36	823750-1	Guard Lower Wheel Blade
37	823779	Bracket Support Lower
38	826532	Knob Locking
39	826626	Pointer
40	813313-5	Screw Pan Hd. M5 x 0.8-6
41	823587	Bracket Trunnion Support
42	*	Lockwasher M8
43	*	Screw Hex Hd. M8 x 1.25-35
44	818470-5	Screw Flat Hd. Cross M5 x 0.8-15
45	826664	Scale Bevel
46	*	Nut Hex M5 x 0.8
47	817393-5	Belt V A40
48	823585	Pulley
49	817391-1	Screw Soc Set M6 x 1.0-10
50	816782	Ring Retaining
51	817530	Bearing Ball
52	823741	Pin
53	821732-1	Screw Hex Hd. M16 x 2.0-55
54	*	Washer M16
55	*	Nut M16
56	823756	Stud

\* Standard hardware item. May be purchased locally.

Key No.	Part No.	Description
57	823598	Hinge Lower
58	818470-3	Screw Flat Hd. M5 x 0.8-10
59	823555	Brush Wheel
60	813313	Screw Pan Hd. M5 x 0.8-12
61	819188	Key 5mm x 20mm
62	823584	Shaft Lower Wheel
63	*	Washer M8
64	823554-1	Base
65	823556	Wheel Lower
66	823762	Bearing Ball
67	823761	Ring Retaining
68	823550	Wheel Upper
69	823763	Nut Hex M12 x 1.25
70	823595	Tire
71	†	Blade 3/8 x 93-1/2
72	823753	Screw Hex Hd. LH M8 x 1.25-25
73	823751	Bolt M10 x 1.5-15 (Special)
74	823583	Catch Door
75	817357	Screw Pan Hd. M4 x 16-8
76		
77		
78		
79	823558	Chute Dust
80	826634	Cover Lower Wheel
81	826536	Knob Catch
82	823771	Screw Pan Hd. Lock M6 x 1-8
83	823552-1	Cover Upper Front
84	816069	Screw Pan Hd. Ty "AB" #6 x 5/8
85	823760	Washer
86	823600	Guard Blade Rear
87	823597	Hinge Upper
88	*	Washer M5
89	823758-8	Cover Upper Back
90	824283	Shaft/Hinge Upper Wheel
91	823569	Pin
92	826537	Bracket Sliding
93	823570	Nut Wing
94	826535	Knob Lock
95	826534	Knob Blade Adjusting
96	826627	Spring Coil
97	826630	Indicator
98	823755	Nut Square
99	AC1000	†Key, Switch
100	826123	Switch Locking
101	*	Screw Pan Hd. #6-32 x 3/8
102	826394	Box Switch
103	*	Lockwasher M5
104	823546	Plate Switch Backing
105	63418	Clamp Cord
106	823563-1	Cord w/Plug
107	823543-1	Cord Power
108	826628	Belt Sanding
109	826629	Platen Sanding
110	827589	Stud Latch
111	SP6174	Owners Manual

† Stock Item - May be secured through the Hardware Department of most Home Depot Stores.

Parts List For RIDGID 14 Inch Band Saws  
Model No. BS14000  
Figure 2

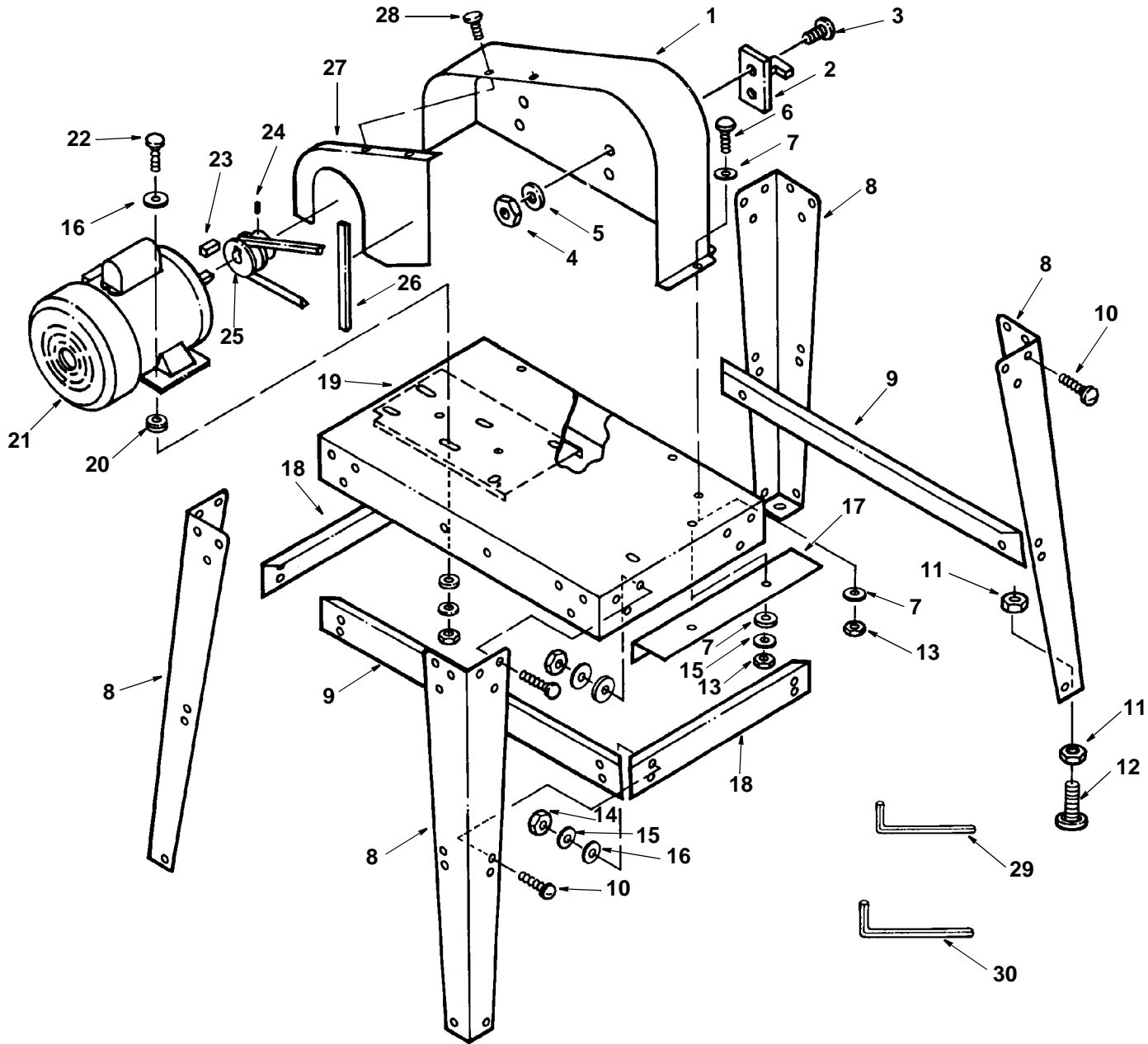

# Repair Parts

## Parts List For RIDGID 14 Inch Band Saw Model No. BS14000

### Figure 2 - Base Components

Always order by Part Number - Not by Key Number

Key No.	Part No.	Description
1	823592-1	Cover Pulley
2	826530	Hanger Blade
3	*	Screw Pan Hd M4 x 0.7-10
4	*	Nut Hex M4 x 0.7
5	*	Washer 4mm
6	*	Screw Pan Hd. M5 x 0.8-12
7	*	Washer M5
8	823773-1	Leg
9	823590-1	Stiffener Long
10	823776	Bolt Carriage M8 x 1.25-16
11	*	Nut Hex 3/8-16
12	803835-1	Foot Leveling
13	*	Nut Hex M5
14	*	Nut Hex M8
15	*	Lockwasher M8

Key No.	Part No.	Description
16	*	Washer M8
17	823593-1	Plate Support
18	823589-1	Stiffener Short
19	823774-1	Stand Top
20	823747	Grommet Rubber
21	823562	Motor
22	*	Screw Hex Hd. M8 x 1.25-35
23	819188	Key 5mm x 20mm
24	817391-1	Screw Set M6 x 1.0-10
25	823740	Pulley Motor
26	823576	Pad
27	823591-1	Cover Pulley Inner
28	*	Screw Pan Hd. M4 x 16-8
29	813317-6	Wrench Hex "L" 3mm
30	813317-8	Wrench Hex "L" 5mm

\* Standard hardware item. May be purchased locally.

## General

**WARNING: For your own safety, turn switch "Off" and remove plug from power source outlet before trouble shooting your band saw.**

Trouble	Probable Cause	Remedy
Blade does not run in the approximate center of the upper wheel.	1. Not tracking properly.	1. Adjust tracking, see Assembly Section, "Adjusting Blade Tracking" section.
Band Saw slows down when cutting	1. Belt too loose. 2. Cutting too small a radius. 3. Dull blade. 4. Overloading motor.	1. Adjust belt tension, see "Assembly" section, "Mounting the Motor". 2. Stop feeding, and back up the material slightly, until the band saw speeds up. 3. Replace blade. 4. Slow down, trying to cut too fast.
Blades braking	1. Too much tension on blade. 2. Kink in blade caused cutting too small a radius or turning the material too fast when cutting.	1. Adjust tension. See "Getting to Know Your Band Saw". 2. Use correct cutting technique. See "Basic Saw Operation" section.
Blade dulls too quickly.	1. Blade guides set too close to teeth. 2. Cutting incorrect material	1. Adjust upper and lower blades guides. See "Assembly" section "Installing the blade".
Band saw vibrates.	1. Too much tension on motor belt	1. Adjust according to "Mounting the Motor" section.

## Wiring Diagram

